

AUTOMOWER G1 2003 2003-01

---

# **SPARE PARTS LIST**

# G

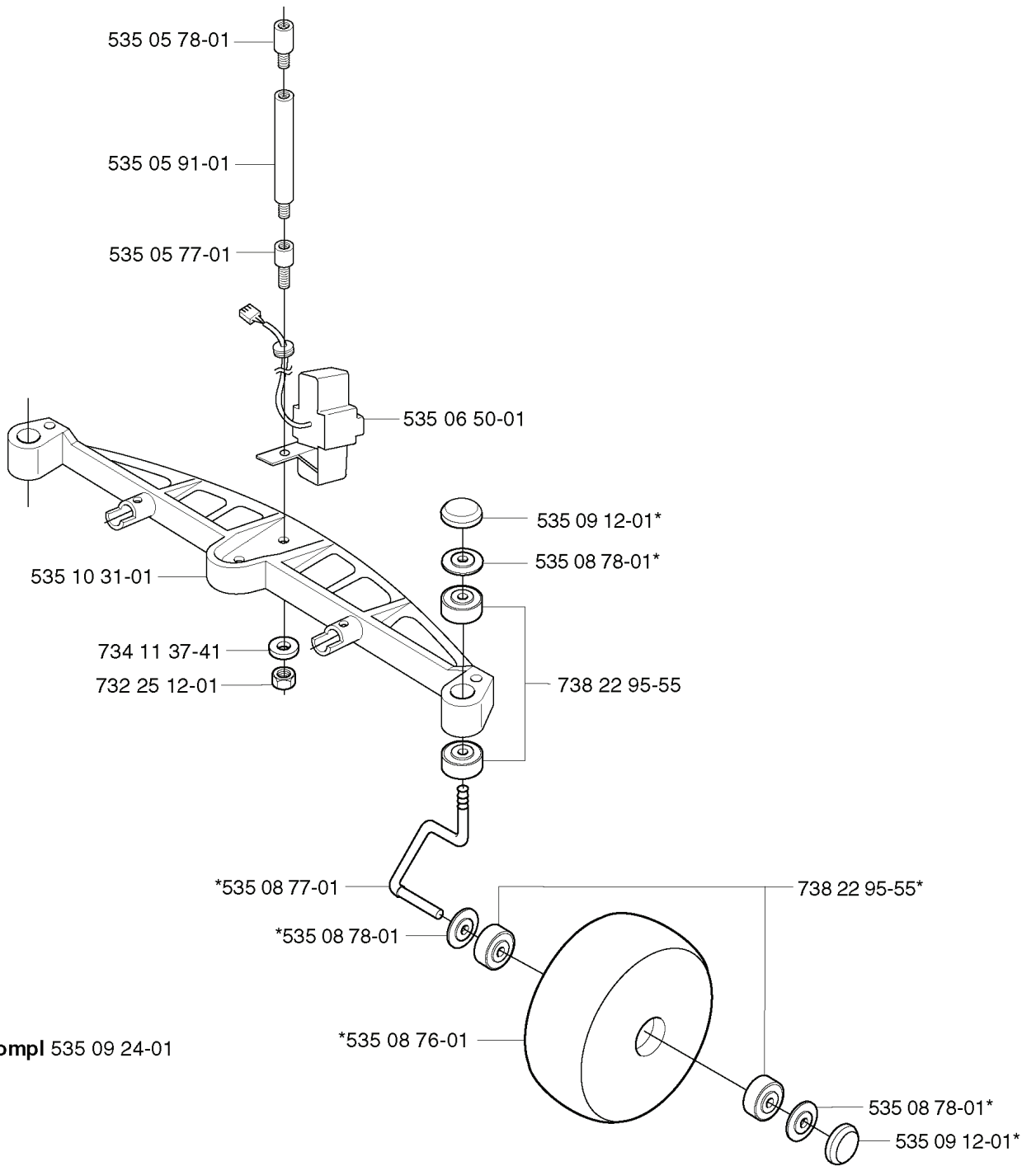

---

REF.	PART NO.	DESCRIPTION	REMARK	QTY.	KIT
535 05 78-01	535057801	ABSORBER		1	
535 05 91-01	535059101	BRACKET		1	
535 05 77-01	535057701	ABSORBER		1	
535 10 31-01	535103101	BRACKET		1	
734 11 37-41	734113741	WASHER		1	
732 25 12-01	732251201	HEXAGON LOCKING NUT		1	
535 08 77-01	535087701	SPINDLE SHAFT		1	
535 09 24-01	535092401	WHEEL		1	
535 08 76-01	535087601	WHEEL		1	
535 09 12-01	535091201	WASHER		1	
535 08 78-01	535087801	COVER WASHER		1	
738 22 95-55	738229555	BALL BEARING		1	
535 06 50-01	535065001	SENSOR		1	

**C**

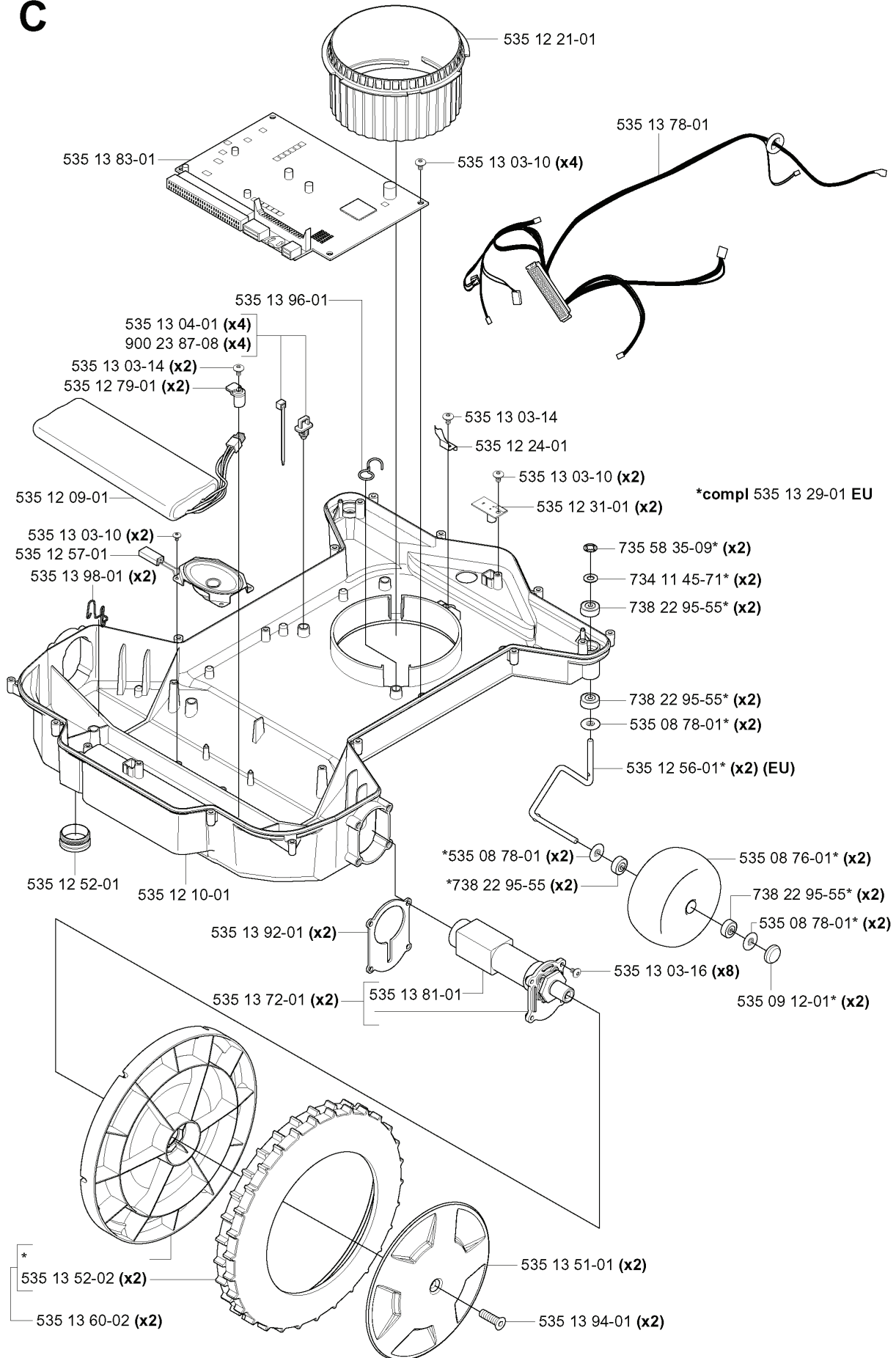

REF.	PART NO.	DESCRIPTION	REMARK	QTY.	KIT
535 1383-01	535138301	CONTROL BOARD		1	
535 1396-01	535139601	CABLE HOLDER		1	
535 1304-01	535130401	ANCHOR		4	
900 2387-08	900238708	TIE WRAP		4	
535 1303-14	535130314	SCREW ITXPANT		2	
535 1279-01	535127901	BRACKET		2	
535 1209-01	535120901	BATTERY		1	
535 1303-10	535130310	SCREW ITXPANT		2	
535 1257-01	535125701	LOUD SPEAKER		1	
535 1398-01	535139801	CABLE HOLDER		2	
535 1252-01	535125201	PLUG		1	
535 1210-01	535121001	CHASSIS		1	
535 1392-01	535139201	GASKET		2	
535 1372-01	535137201	DRIVE MOTOR		2	
535 1352-02	535135202	TIRE		2	
535 1360-02	535136002	GEAR WHEEL		2	
535 1394-01	535139401	SCREW IHCSFM		2	
535 1351-01	535135101	HUB CAP		2	
535 1381-01	535138101	DRIVE MOTOR		1	
535 1303-16	535130316	SCREW ITXPANT		8	
535 0912-01	535091201	WASHER		2	
535 0878-01	535087801	COVER WASHER		2	
535 0876-01	535087601	WHEEL		2	
535 1256-01	535125601	SPINDLE SHAFT	EU	2	
738 2295-55	738229555	BALL BEARING		2	
734 1145-71	734114571	WASHER		2	
735 5835-09	735583509	WASHER		2	
535 1231-01	535123101	SENSOR CARD		2	
535 1224-01	535122401	LOCKING SPRING		1	
535 1221-01	535122101	NUT		1	
535 1378-01	535137801	WIRING		1	
535 1329-01	535132901	KIT	EU	1	

**A** \*compl 535 09 77-01



\*535 08 58-01

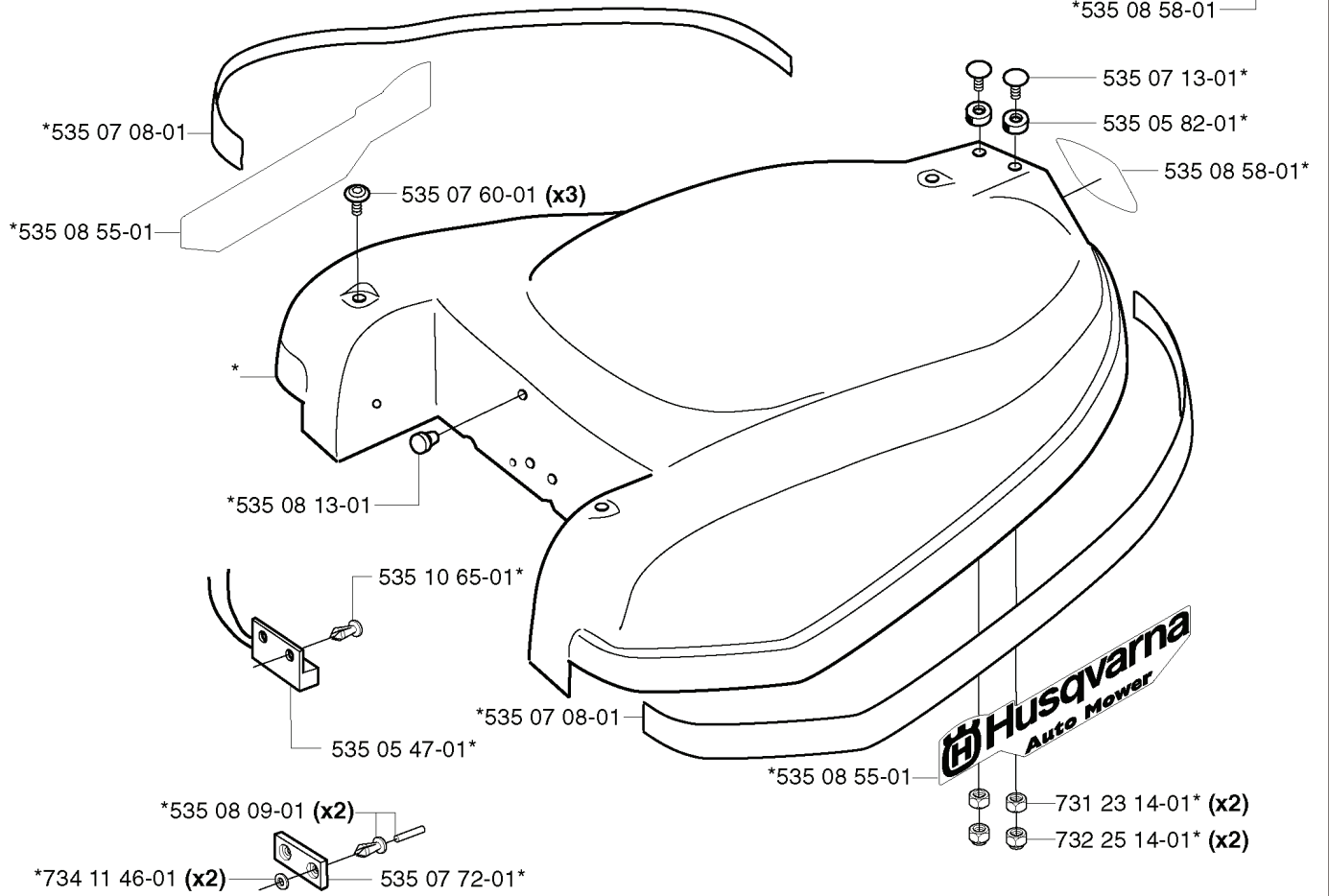

REF.	PART NO.	DESCRIPTION	REMARK	QTY.	KIT
535 09 77-01	535097701	COVER		1	
535 07 08-01	535070801	TAPE		1	
734 11 46-01	734114601	WASHER		2	
535 07 72-01	535077201	RAIL		1	
535 08 09-01	535080901	RIVET		2	
535 05 47-01	535054701	SWITCH		1	
535 10 65-01	535106501	RIVET		1	
535 08 13-01	535081301	BUFFER		1	
535 07 60-01	535076001	SCREW		3	
732 25 14-01	732251401	HEXAGON LOCKING NUT		2	
731 23 14-01	731231401	HEXAGON NUT		2	
535 05 82-01	535058201	WASHER		1	
535 07 13-01	535071301	SCREW		1	
535 08 58-01	535085801	DECAL		1	
535 08 55-01	535085501	DECAL		2	

**B** \*compl 535 09 88-01

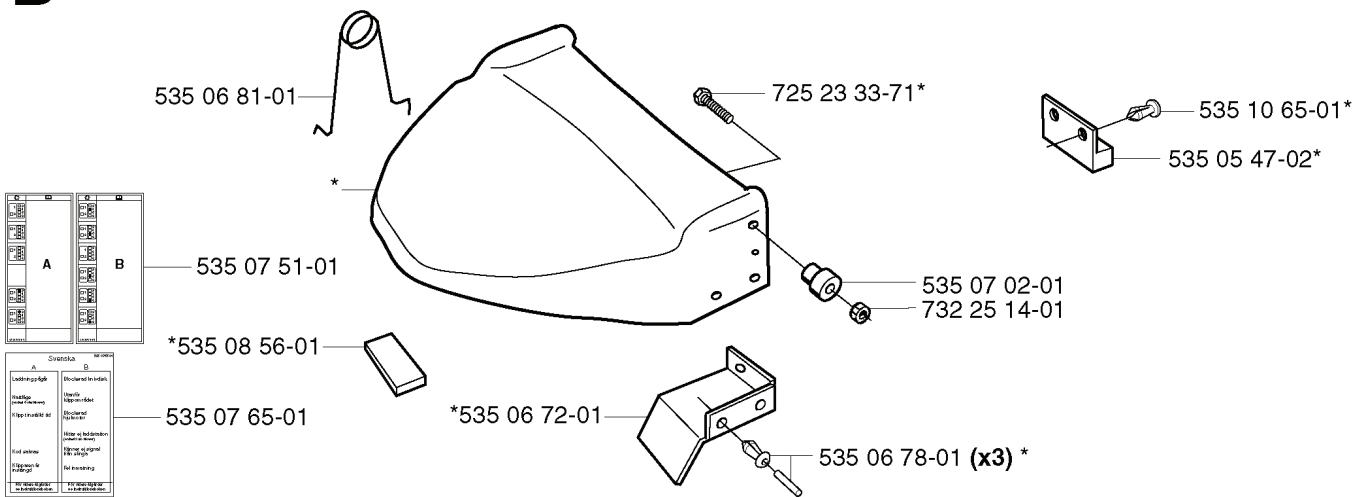

---

REF.	PART NO.	DESCRIPTION	REMARK	QTY.	KIT
535 09 88-01	535098801	COVER		1	
535 06 81-01	535068101	SPRING		1	
535 07 51-01	535075101	DECAL		1	
535 08 56-01	535085601	BUMPER		1	
535 07 65-01	535076501	DECAL		1	
535 06 72-01	535067201	COVER		1	
535 06 78-01	535067801	RIVET		3	
732 25 14-01	732251401	HEXAGON LOCKING NUT		1	
535 07 02-01	535070201	BUSHING		1	
725 23 33-71	725233371	SCREW EHHM		1	
535 05 47-02	535054702	MAGNET		1	
535 10 65-01	535106501	RIVET		1	

# D

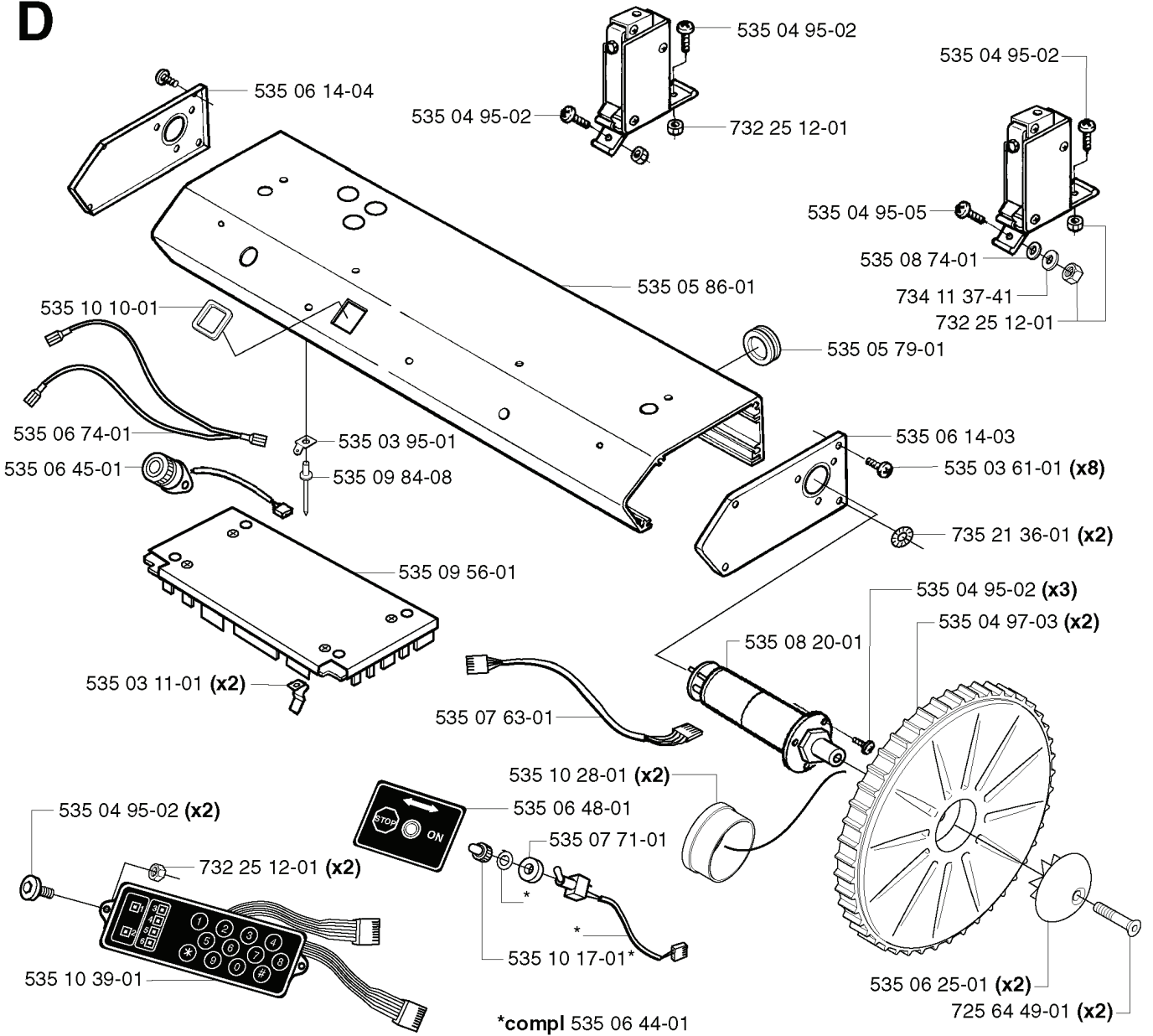

REF.	PART NO.	DESCRIPTION	REMARK	QTY.	KIT
535 06 14-04	535061404	END		1	
535 10 10-01	535101001	GASKET		1	
535 06 74-01	535067401	CABLE		1	
535 06 45-01	535064501	BUZZER		1	
535 03 11-01	535031101	SPRING		2	
535 04 95-02	535049502	SCREW IH PANM		2	
535 10 39-01	535103901	KEYBOARD		1	
535 06 44-01	535064401	SWITCH		1	
535 10 17-01	535101701	SWITCH		1	
535 07 71-01	535077101	WASHER		1	
535 06 48-01	535064801	DECAL		1	
535 10 28-01	535102801	PROTECTION		2	
535 07 63-01	535076301	CABLE ASSY		1	
535 09 56-01	535095601	PRINTED CIRCUIT ASSY		1	
535 09 84-08	535098408	RIVET		1	
535 03 95-01	535039501	CLIP		1	
732 25 12-01	732251201	HEXAGON LOCKING NUT		1	
535 05 86-01	535058601	BOX		1	
535 08 20-01	535082001	ENGINE	Motor w/o gearbox 535 10 66-01	1	
725 64 49-01	725644901	SCREW IHCSFM		2	
535 06 25-01	535062501	WASHER		2	
535 04 97-03	535049703	GEAR WHEEL		2	
735 21 36-01	735213601	LOCKWASHER		2	
535 03 61-01	535036101	SCREW		8	
535 06 14-03	535061403	END		1	
535 05 79-01	535057901	GROMMET		1	
734 11 37-41	734113741	WASHER		1	
535 08 74-01	535087401	WASHER		1	
535 04 95-05	535049505	SCREW IH PANM		1	

**C**

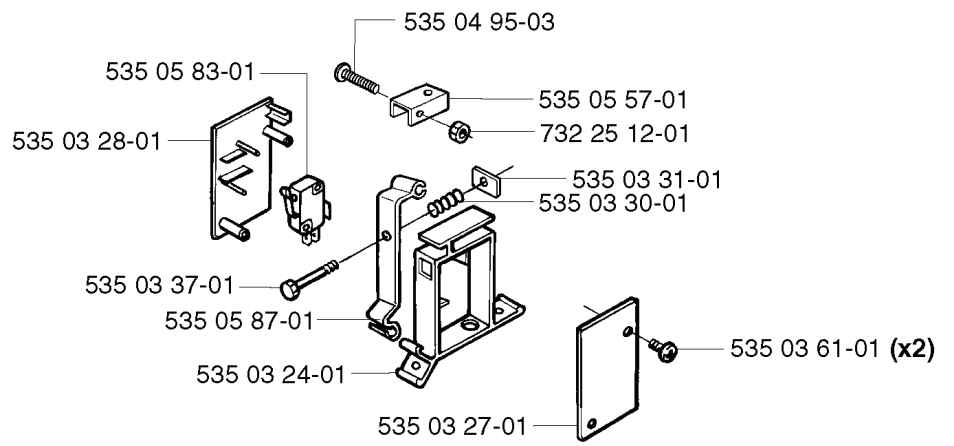
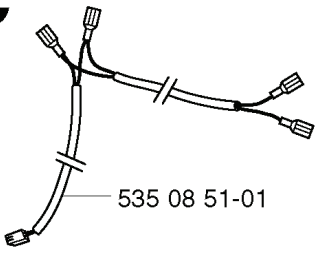

---

REF.	PART NO.	DESCRIPTION	REMARK	QTY.	KIT
535 08 51-01	535085101	CABLE ASSY		1	
535 05 83-01	535058301	SWITCH		1	
535 03 28-01	535032801	COVER		1	
535 03 37-01	535033701	SCREW		1	
535 05 87-01	535058701	LEVER		1	
535 03 24-01	535032401	BRACKET		1	
535 03 27-01	535032701	COVER		1	
535 03 61-01	535036101	SCREW		2	
535 03 30-01	535033001	SPRING		1	
535 03 31-01	535033101	NUT		1	
732 25 12-01	732251201	HEXAGON LOCKING NUT		1	
535 05 57-01	535055701	BRACKET		1	
535 04 95-03	535049503	SCREW IH PANM		1	

# E

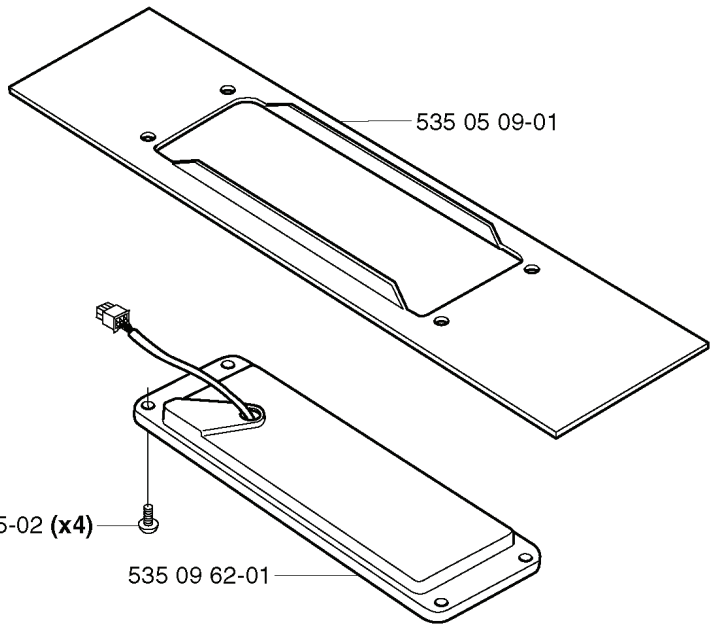
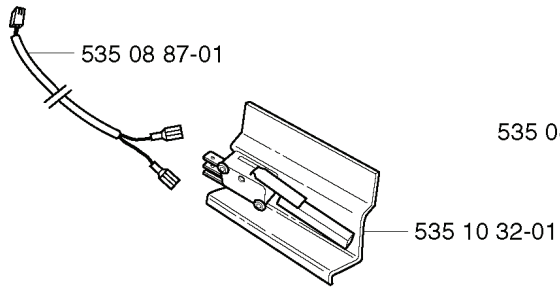
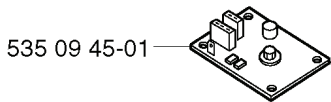
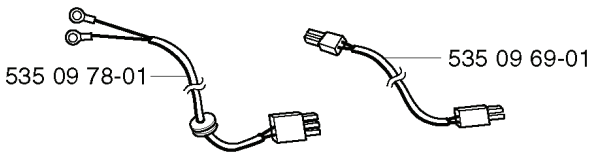

---

REF.	PART NO.	DESCRIPTION	REMARK	QTY.	KIT
535 09 78-01	535097801	CABLE		1	
535 09 45-01	535094501	PRINTED CIRCUIT CARD		1	
535 08 87-01	535088701	CABLE ASSY		1	
535 10 32-01	535103201	SWITCH		1	
535 04 95-02	535049502	SCREW IHANM		4	
535 09 69-01	535096901	CABLE ASSY		1	
535 09 62-01	535096201	BATTERY		1	
535 05 09-01	535050901	COVER		1	

**J**

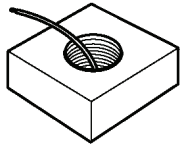

535 04 16-01

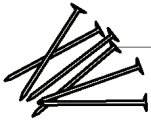

535 08 88-01



535 05 05-01

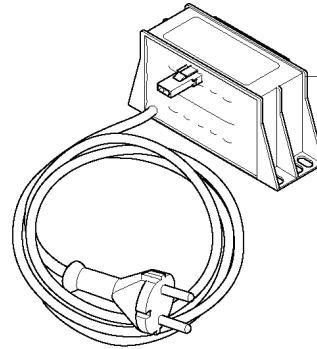

535 10 63-01 (EU)  
535 10 63-02 (GB)  
535 10 63-03 (CH)

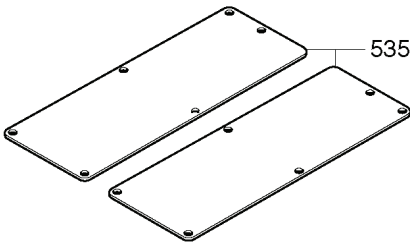

535 10 30-01



535 10 35-01



535 07 89-01

---

REF.	PART NO.	DESCRIPTION	REMARK	QTY.	KIT
535 04 16-01	535041601	WIRE		1	
535 08 88-01	535088801	PIN RETAINING SCREW		1	
535 10 30-01	535103001	PLATE		1	
535 10 35-01	535103501	PLASTIC CARD KIT		1	
535 05 05-01	535050501	STAPLE		1	
535 10 63-01	535106301	TRANSFORMER	EU	1	
535 10 63-02	535106302	TRANSFORMER	GB	1	
535 10 63-03	535106303	TRANSFORMER	CH	1	
535 07 89-01	535078901	WIRE		1	

**H**

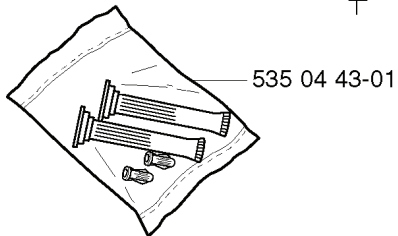
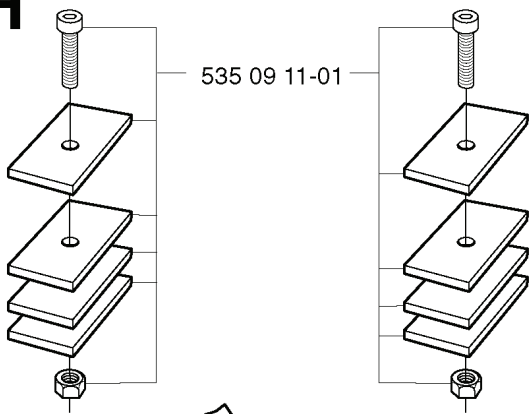

505 69 99-90



---

REF.	PART NO.	DESCRIPTION	REMARK	QTY.	KIT
535 09 11-01	535091101	COUNTERWEIGHT		1	
535 04 43-01	535044301	COUPLER		1	
505 69 99-90	505699990	BAG		1	

**D**

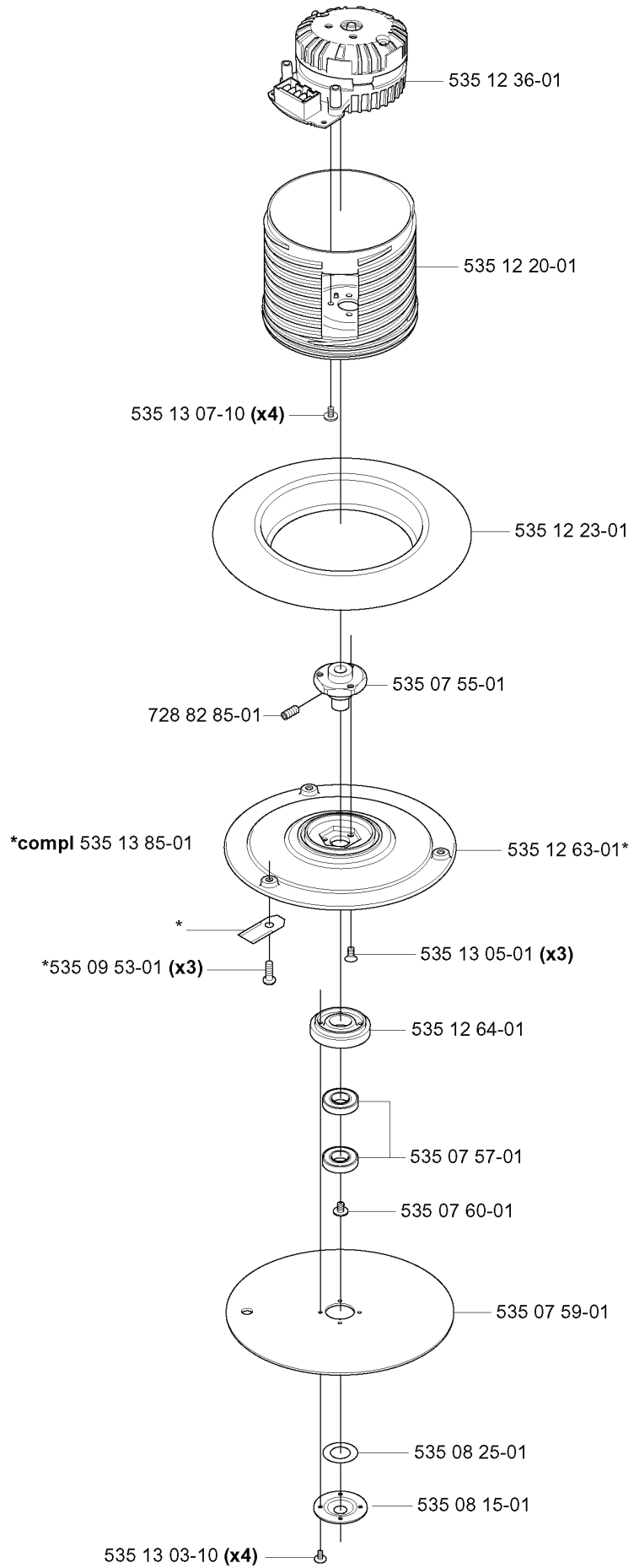

REF.	PART NO.	DESCRIPTION	REMARK	QTY.	KIT
535 13 07-10	535130710	SCREW		4	
728 82 85-01	728828501	SCREW IHSETM		1	
535 13 85-01	535138501	KIT		1	
535 09 53-01	535095301	SCREW		3	
535 13 03-10	535130310	SCREW ITXPANT		4	
535 08 15-01	535081501	COVER WASHER		1	
535 08 25-01	535082501	GASKET		1	
535 07 59-01	535075901	SKID PLATE		1	
535 07 60-01	535076001	SCREW		1	
535 07 57-01	535075701	BALL BEARING		1	
535 07 57-01	593080801	BALL BEARING	Tube 50 pcs	1	
535 12 64-01	535126401	HOUSING		1	
535 13 05-01	535130501	SCREW		3	
535 12 63-01	535126301	CUTTING DISC		1	
535 07 55-01	535075501	HUB		1	
535 12 23-01	535122301	RUBBER GAITERS		1	
535 12 20-01	535122001	MOTOR BOWL		1	
535 12 36-01	535123601	MOTOR ASSY		1	