

AUTOMOWER G1 2001 2001-01

SPARE PARTS LIST

G

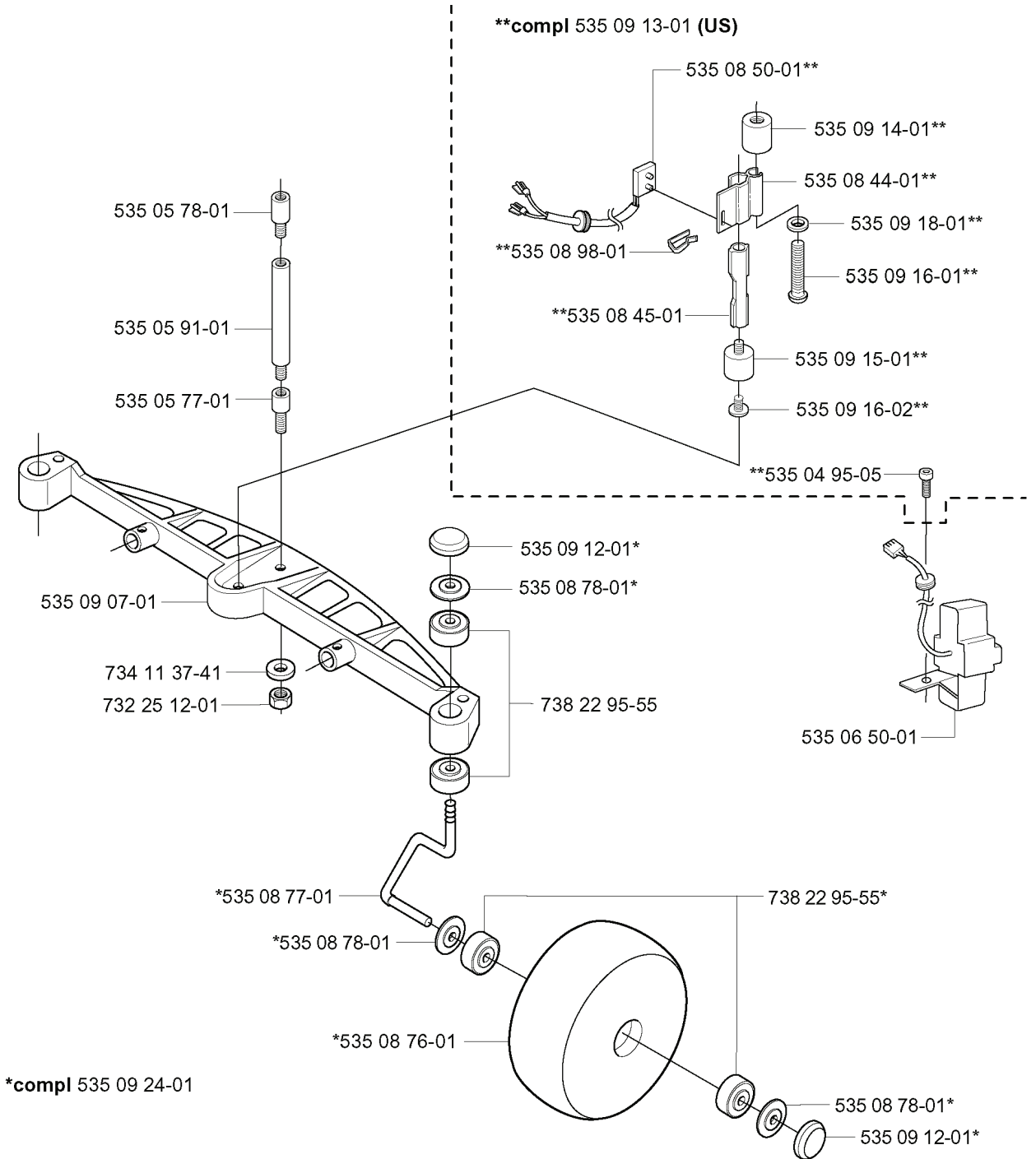

| REF. | PART NO. | DESCRIPTION | REMARK | QTY. | KIT |
|--------------|-----------|---------------------|--------|------|-----|
| 535 05 78-01 | 535057801 | ABSORBER | | 1 | |
| 535 05 91-01 | 535059101 | BRACKET | | 1 | |
| 535 05 77-01 | 535057701 | ABSORBER | | 1 | |
| 535 09 07-01 | 535090701 | BRACKET | | 1 | |
| 734 11 37-41 | 734113741 | WASHER | | 1 | |
| 732 25 12-01 | 732251201 | HEXAGON LOCKING NUT | | 1 | |
| 535 08 77-01 | 535087701 | SPINDLE SHAFT | | 1 | |
| 535 08 76-01 | 535087601 | WHEEL | | 1 | |
| 535 09 24-01 | 535092401 | WHEEL | | 1 | |
| 738 22 95-55 | 738229555 | BALL BEARING | | 1 | |
| 535 06 50-01 | 535065001 | SENSOR | | 1 | |
| 535 08 78-01 | 535087801 | COVER WASHER | | 1 | |
| 535 09 12-01 | 535091201 | WASHER | | 1 | |
| 535 08 45-01 | 535084501 | ROD | | 1 | |
| 535 08 98-01 | 535089801 | CLIP | | 1 | |
| 535 09 13-01 | 535091301 | LIFT SENSOR | US | 1 | |
| 535 08 50-01 | 535085001 | CABLE ASSY | | 1 | |
| 535 09 14-01 | 535091401 | DAMPER | | 1 | |
| 535 08 44-01 | 535084401 | BRACKET | | 1 | |
| 535 09 18-01 | 535091801 | WASHER | | 1 | |
| 535 09 16-01 | 535091601 | SCREW | | 1 | |
| 535 09 15-01 | 535091501 | BUMPER | | 1 | |
| 535 09 16-02 | 535091602 | SCREW | | 1 | |
| 534 04 95-05 | 534049505 | | | 1 | |

A

*compl 535 09 77-01
*compl 535 09 77-02 (US)

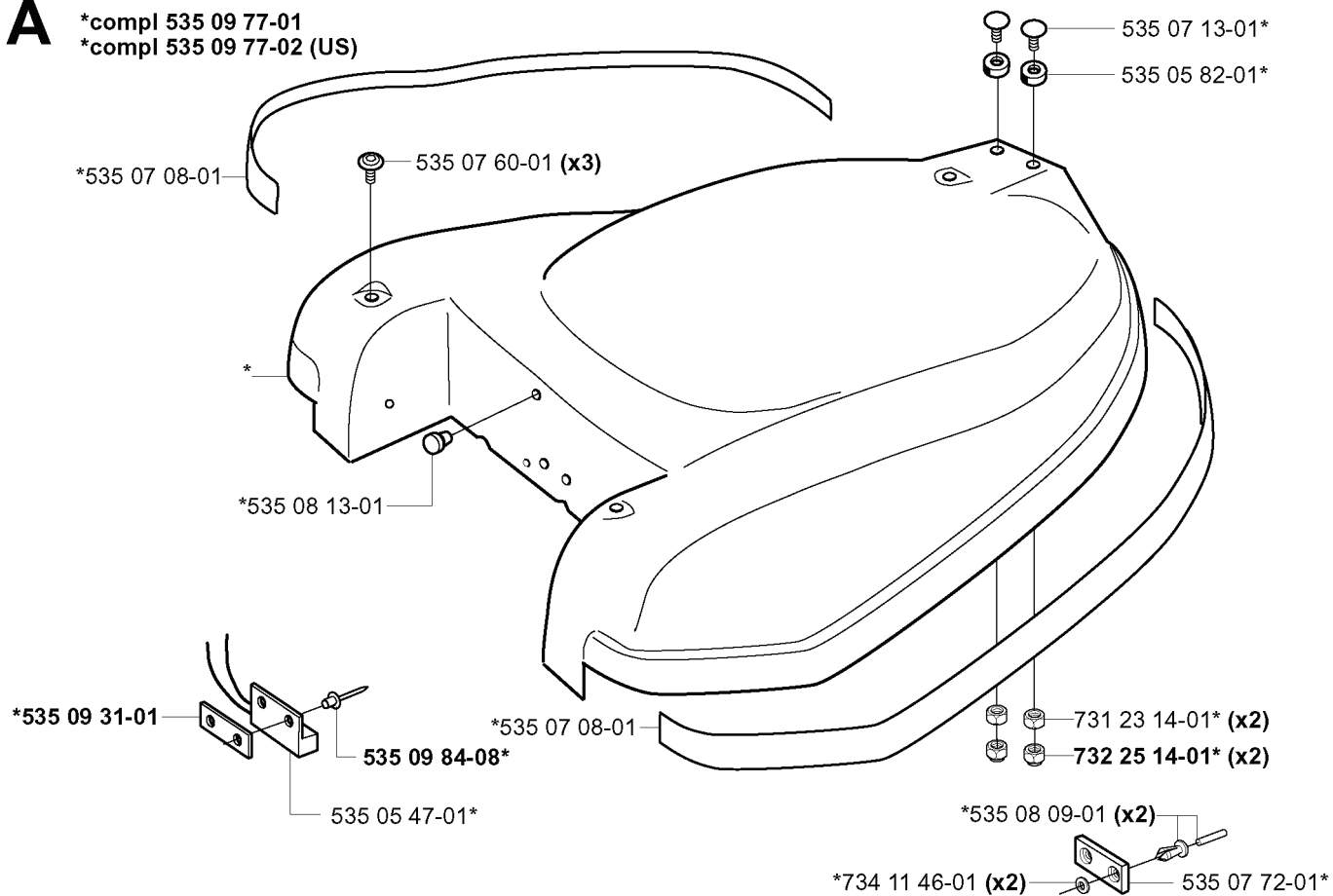

| REF. | PART NO. | DESCRIPTION | REMARK | QTY. | KIT |
|--------------|-----------|---------------------|--------|------|-----|
| 535 09 77-01 | 535097701 | COVER | | 1 | |
| 535 09 77-02 | 535097702 | COVER | US | 1 | |
| 535 07 08-01 | 535070801 | TAPE | | 1 | |
| 535 07 60-01 | 535076001 | SCREW | | 3 | |
| 535 08 13-01 | 535081301 | BUFFER | | 1 | |
| 535 09 31-01 | 535093101 | WASHER | | 1 | |
| 535 05 47-01 | 535054701 | SWITCH | | 1 | |
| 535 09 84-08 | 535098408 | RIVET | | 1 | |
| 734 11 46-01 | 734114601 | WASHER | | 2 | |
| 535 07 72-01 | 535077201 | RAIL | | 1 | |
| 535 08 09-01 | 535080901 | RIVET | | 2 | |
| 732 25 14-01 | 732251401 | HEXAGON LOCKING NUT | | 2 | |
| 731 23 14-01 | 731231401 | HEXAGON NUT | | 2 | |
| 535 05 82-01 | 535058201 | WASHER | | 1 | |
| 535 07 13-01 | 535071301 | SCREW | | 1 | |

E

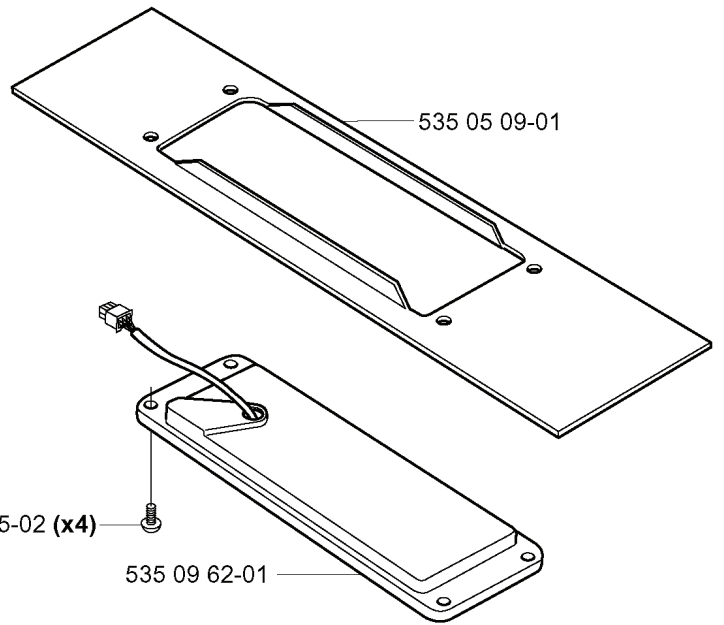
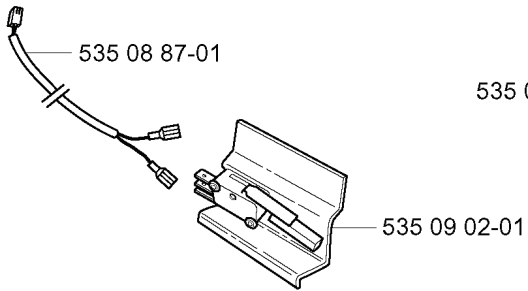
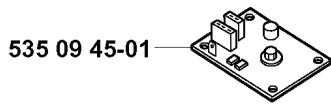
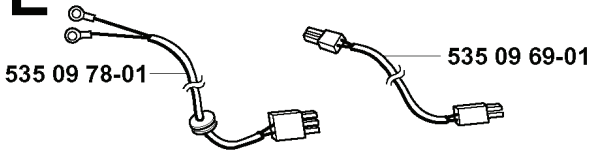

| REF. | PART NO. | DESCRIPTION | REMARK | QTY. | KIT |
|--------------|-----------|----------------------|--------|------|-----|
| 535 09 78-01 | 535097801 | CABLE | | 1 | |
| 535 09 45-01 | 535094501 | PRINTED CIRCUIT CARD | | 1 | |
| 535 08 87-01 | 535088701 | CABLE ASSY | | 1 | |
| 535 09 02-01 | 535090201 | SWITCH | | 1 | |
| 535 09 69-01 | 535096901 | CABLE ASSY | | 1 | |
| 535 04 95-02 | 535049502 | SCREW IH PANM | | 4 | |
| 535 09 62-01 | 535096201 | BATTERY | | 1 | |
| 535 05 09-01 | 535050901 | COVER | | 1 | |

D

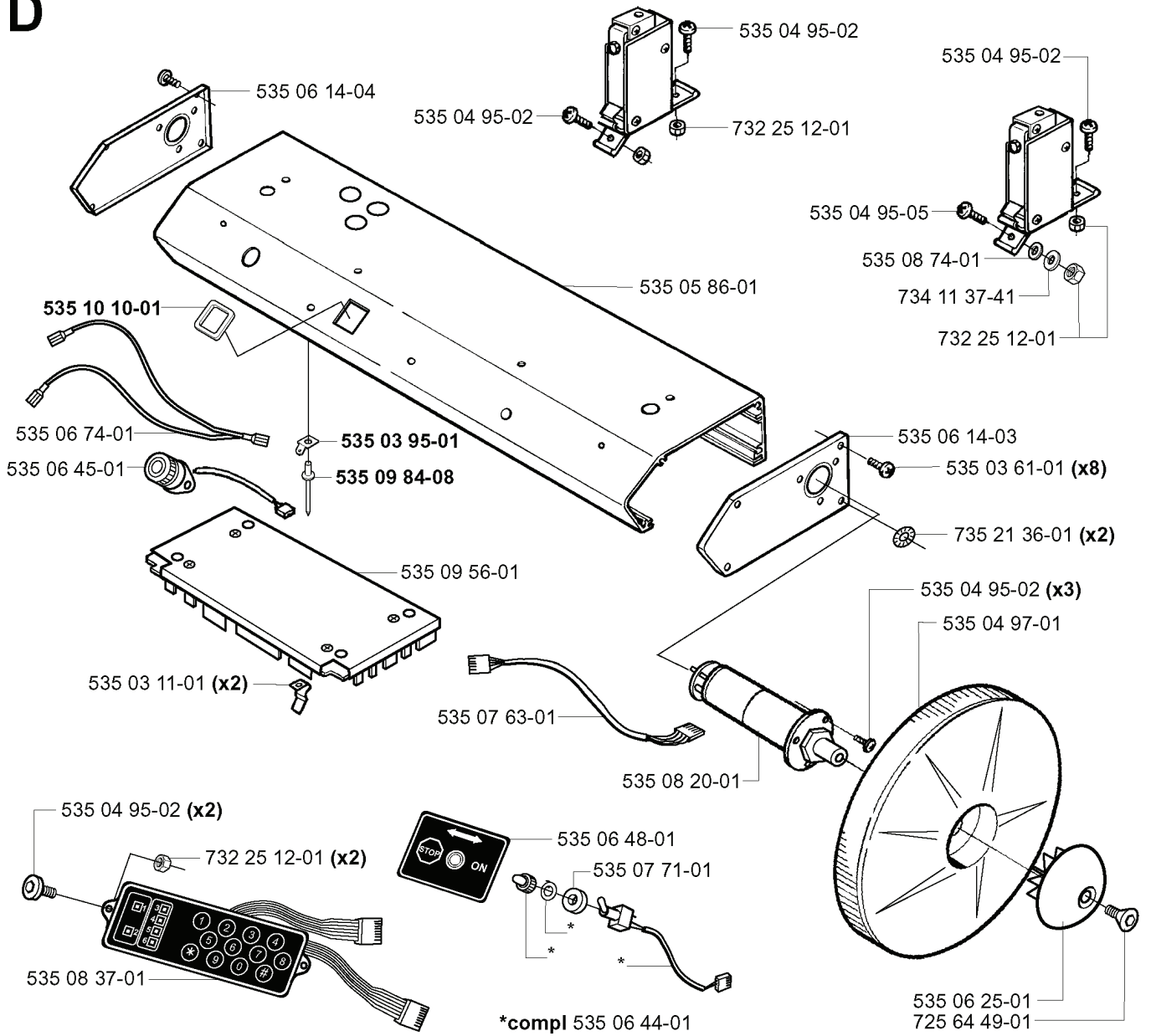

| REF. | PART NO. | DESCRIPTION | REMARK | QTY. | KIT |
|--------------|-----------|----------------------|--------------------------------|------|-----|
| 535 06 14-04 | 535061404 | END | | 1 | |
| 535 10 10-01 | 535101001 | GASKET | | 1 | |
| 535 06 74-01 | 535067401 | CABLE | | 1 | |
| 535 06 45-01 | 535064501 | BUZZER | | 1 | |
| 535 03 11-01 | 535031101 | SPRING | | 2 | |
| 535 04 95-02 | 535049502 | SCREW IH PANM | | 2 | |
| 535 08 37-01 | 535083701 | KEYBOARD | | 1 | |
| 535 06 44-01 | 535064401 | SWITCH | | 1 | |
| 535 07 71-01 | 535077101 | WASHER | | 1 | |
| 535 06 48-01 | 535064801 | DECAL | | 1 | |
| 535 08 20-01 | 535082001 | ENGINE | Motor w/o gearbox 535 10 66-01 | 1 | |
| 535 07 63-01 | 535076301 | CABLE ASSY | | 1 | |
| 535 09 56-01 | 535095601 | PRINTED CIRCUIT ASSY | | 1 | |
| 535 09 84-08 | 535098408 | RIVET | | 1 | |
| 535 03 95-01 | 535039501 | CLIP | | 1 | |
| 732 25 12-01 | 732251201 | HEXAGON LOCKING NUT | | 1 | |
| 535 05 86-01 | 535058601 | BOX | | 1 | |
| 725 64 49-01 | 725644901 | SCREW IHCSFM | | 1 | |
| 535 06 25-01 | 535062501 | WASHER | | 1 | |
| 535 04 97-01 | 535049701 | GEAR WHEEL | | 1 | |
| 735 21 36-01 | 735213601 | LOCKWASHER | | 2 | |
| 535 03 61-01 | 535036101 | SCREW | | 8 | |
| 535 06 14-03 | 535061403 | END | | 1 | |
| 734 11 37-41 | 734113741 | WASHER | | 1 | |
| 535 08 74-01 | 535087401 | WASHER | | 1 | |
| 535 04 95-05 | 535049505 | SCREW IH PANM | | 1 | |

| REF. | PART NO. | DESCRIPTION | REMARK | QTY. | KIT |
|--------------|-----------|---------------------|--------|------|-----|
| 535 04 16-01 | 535041601 | WIRE | | 1 | |
| 535 08 88-01 | 535088801 | PIN RETAINING SCREW | | 1 | |
| 535 08 79-01 | 535087901 | SCREEN | | 1 | |
| 535 09 85-01 | 535098501 | PLASTIC CARD, KIT | | 1 | |
| 535 07 65-01 | 535076501 | DECAL | | 1 | |
| 535 07 89-01 | 535078901 | WIRE | | 1 | |
| 535 07 85-01 | 535078501 | TRANSFORMER | EU | 1 | |
| 535 07 86-01 | 535078601 | TRANSFORMER | GB | 1 | |
| 535 07 87-01 | 535078701 | TRANSFORMER | CH | 1 | |
| 535 07 88-01 | 535078801 | TRANSFORMER | US | 1 | |
| 535 05 05-01 | 535050501 | STAPLE | | 1 | |

K

*compl 535 09 50-01

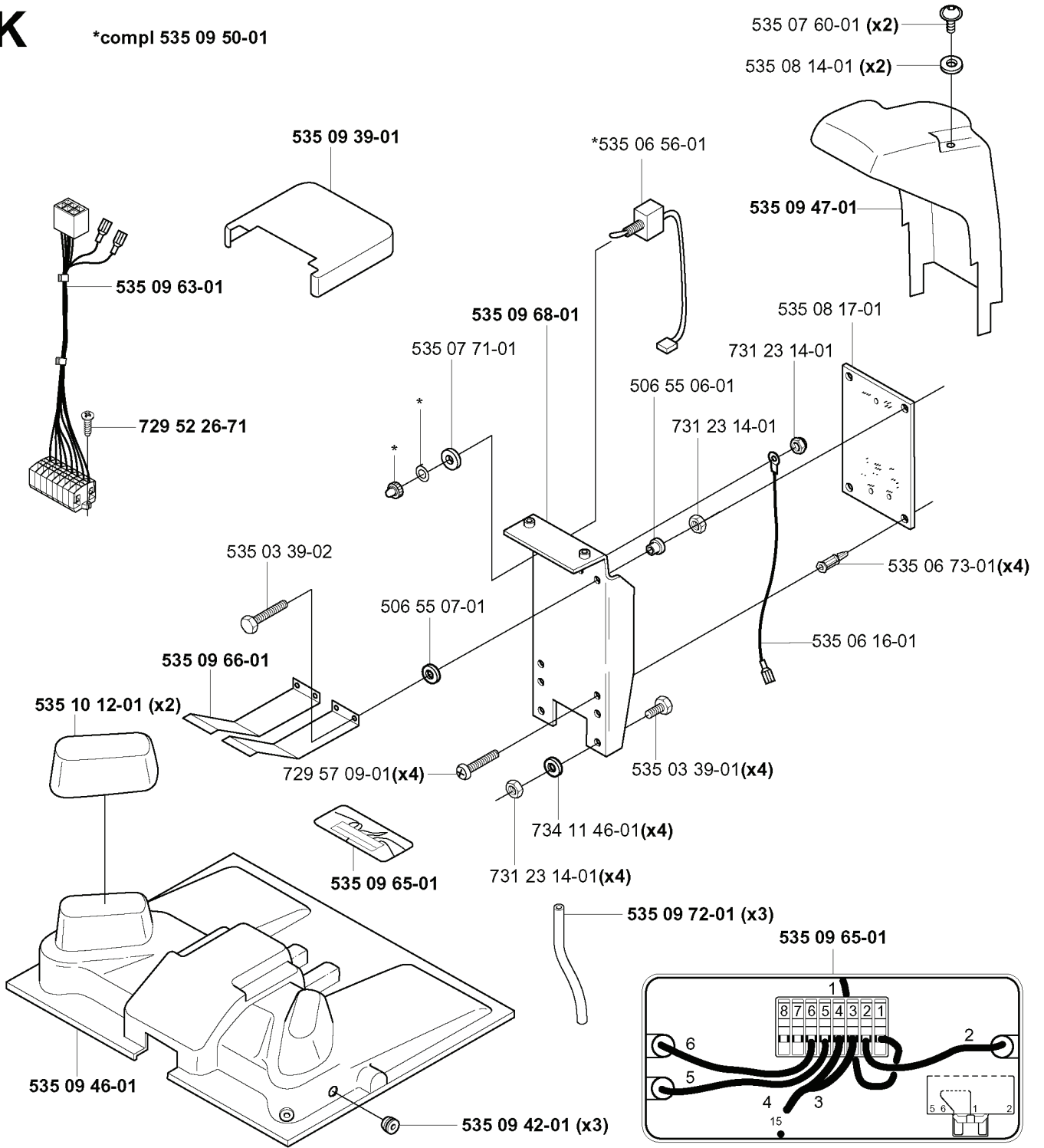

| REF. | PART NO. | DESCRIPTION | REMARK | QTY. | KIT |
|--------------|-----------|----------------------|--------|------|-----|
| 535 09 50-01 | 535095001 | CHARGING STATION | | 1 | |
| 535 09 39-01 | 535093901 | COVER | | 1 | |
| 535 09 63-01 | 535096301 | CABLE ASSY | | 1 | |
| 729 52 26-71 | 729522671 | SCREW CRPANT | | 1 | |
| 535 03 39-02 | 535033902 | SCREW IHANM | | 1 | |
| 535 09 66-01 | 535096601 | PLATE | | 1 | |
| 535 10 12-01 | 535101201 | BRACKET | | 2 | |
| 535 09 46-01 | 535094601 | COVER | | 1 | |
| 535 09 42-01 | 535094201 | GROMMET | | 3 | |
| 729 57 09-01 | 729570901 | SCREW CCRPANT | | 4 | |
| 506 55 07-01 | 506550701 | INSULATING WASHER | | 1 | |
| 535 07 71-01 | 535077101 | WASHER | | 1 | |
| 535 09 68-01 | 535096801 | BRACKET | | 1 | |
| 535 06 56-01 | 535065601 | SWITCH | | 1 | |
| 535 07 60-01 | 535076001 | SCREW | | 2 | |
| 535 08 14-01 | 535081401 | WASHER | | 2 | |
| 535 09 47-01 | 535094701 | COVER | | 1 | |
| 535 08 17-01 | 535081701 | PRINTED CIRCUIT CARD | | 1 | |
| 506 55 06-01 | 506550601 | PLUG | | 1 | |
| 731 23 14-01 | 731231401 | HEXAGON NUT | | 1 | |
| 535 06 73-01 | 535067301 | SPACER | | 4 | |
| 535 06 16-01 | 535061601 | CABLE | | 1 | |
| 535 03 39-01 | 535033901 | SCREW IHANM | | 4 | |
| 734 11 46-01 | 734114601 | WASHER | | 4 | |
| 535 09 72-01 | 535097201 | HOSE | | 3 | |
| 535 09 65-01 | 535096501 | DECAL | | 1 | |

C

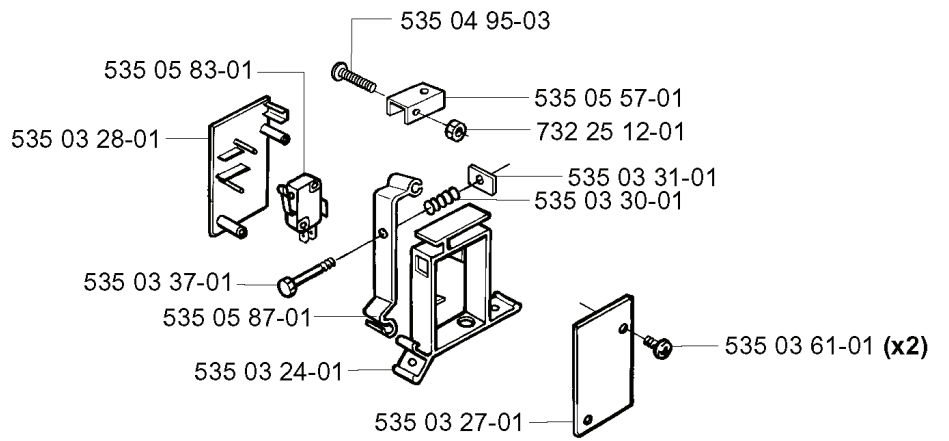
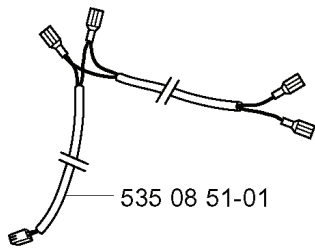

| REF. | PART NO. | DESCRIPTION | REMARK | QTY. | KIT |
|--------------|-----------|---------------------|--------|------|-----|
| 535 08 51-01 | 535085101 | CABLE ASSY | | 1 | |
| 535 03 27-01 | 535032701 | COVER | | 1 | |
| 535 03 24-01 | 535032401 | BRACKET | | 1 | |
| 535 05 87-01 | 535058701 | LEVER | | 1 | |
| 535 03 37-01 | 535033701 | SCREW | | 1 | |
| 535 03 28-01 | 535032801 | COVER | | 1 | |
| 535 05 83-01 | 535058301 | SWITCH | | 1 | |
| 535 04 95-03 | 535049503 | SCREW IH PANM | | 1 | |
| 535 05 57-01 | 535055701 | BRACKET | | 1 | |
| 732 25 12-01 | 732251201 | HEXAGON LOCKING NUT | | 1 | |
| 535 03 31-01 | 535033101 | NUT | | 1 | |
| 535 03 30-01 | 535033001 | SPRING | | 1 | |
| 535 03 61-01 | 535036101 | SCREW | | 2 | |

H

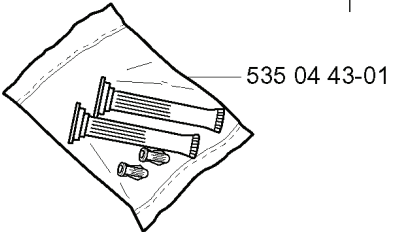
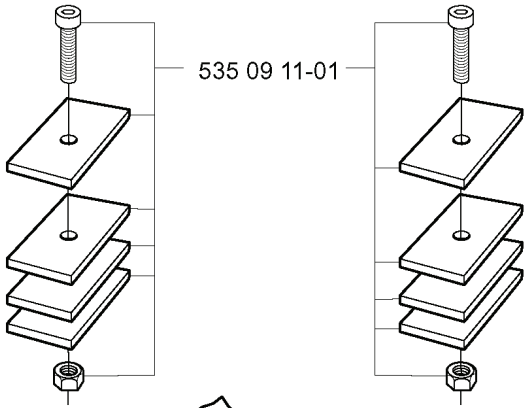

505 69 99-90



| REF. | PART NO. | DESCRIPTION | REMARK | QTY. | KIT |
|--------------|-----------|---------------|--------|------|-----|
| 535 09 11-01 | 535091101 | COUNTERWEIGHT | | 1 | |
| 535 04 43-01 | 535044301 | COUPLER | | 1 | |
| 505 69 99-90 | 505699990 | BAG | | 1 | |

F

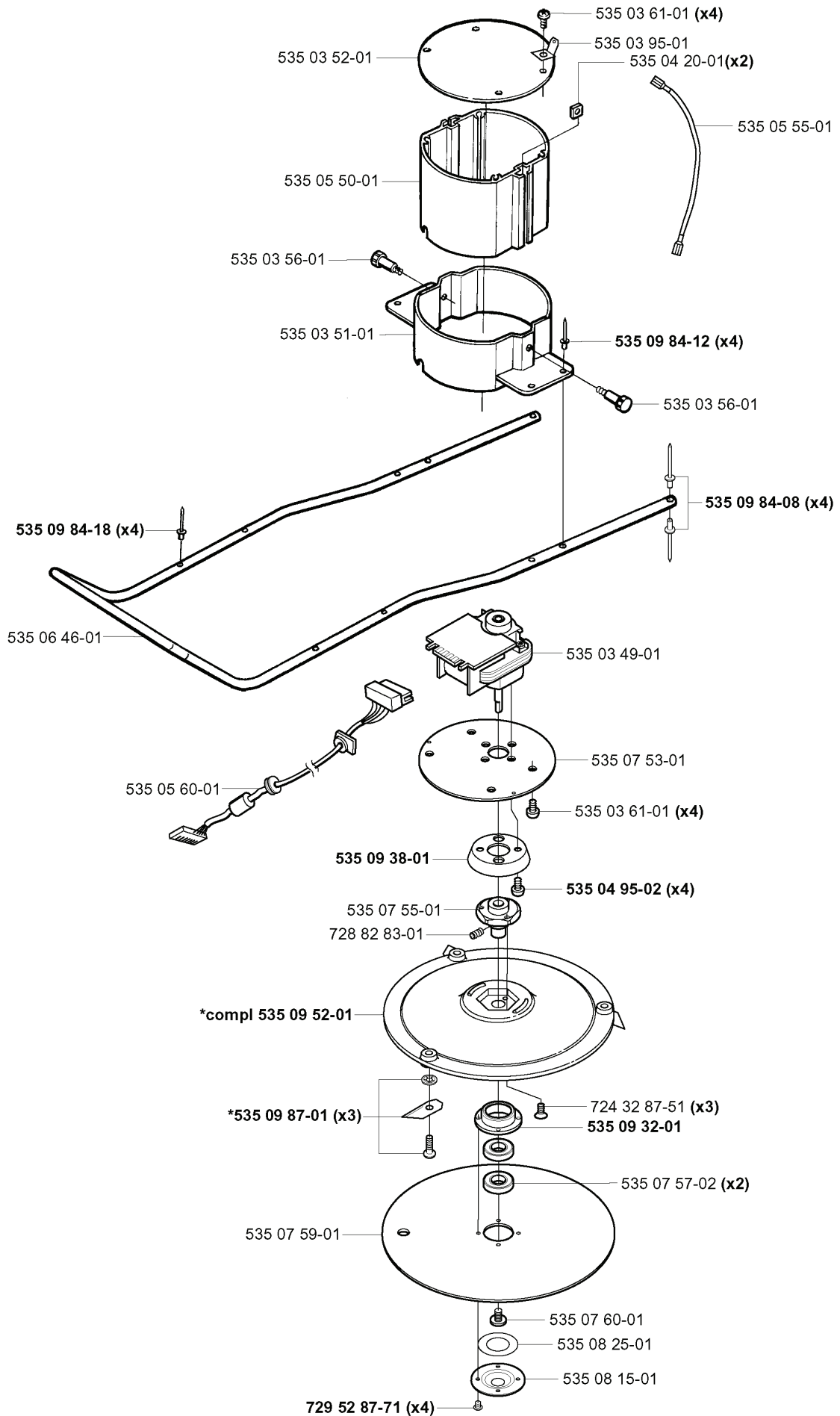

| REF. | PART NO. | DESCRIPTION | REMARK | QTY. | KIT |
|--------------|-----------|---------------|-------------|------|-----|
| 535 03 52-01 | 535035201 | COVER | | 1 | |
| 535 05 50-01 | 535055001 | PIPE | | 1 | |
| 535 03 56-01 | 535035601 | KNOB | | 1 | |
| 535 03 51-01 | 535035101 | PIPE | | 1 | |
| 535 09 84-18 | 535098418 | RIVET | | 4 | |
| 535 06 46-01 | 535064601 | PIPE | | 1 | |
| 535 05 60-01 | 535056001 | CABLE | | 1 | |
| 535 09 38-01 | 535093801 | PROTECTION | | 1 | |
| 535 07 55-01 | 535075501 | HUB | | 1 | |
| 728 82 83-01 | 728828301 | SCREW IHSETM | | 1 | |
| 535 09 52-01 | 535095201 | BLADE | | 1 | |
| 535 09 87-01 | 535098701 | BLADE SET | | 3 | |
| 535 07 59-01 | 535075901 | SKID PLATE | | 1 | |
| 729 52 87-71 | 729528771 | SCREW CCRPANT | | 4 | |
| 535 08 15-01 | 535081501 | COVER WASHER | | 1 | |
| 535 08 25-01 | 535082501 | GASKET | | 1 | |
| 535 07 60-01 | 535076001 | SCREW | | 1 | |
| 535 07 57-02 | 535075702 | BALL BEARING | | 2 | |
| 535 07 57-02 | 593080801 | BALL BEARING | Tube 50 pcs | 1 | |
| 535 09 32-01 | 535093201 | BEARING BOX | | 1 | |
| 724 32 87-51 | 724328751 | SCREW CRCFSM | | 3 | |
| 535 04 95-02 | 535049502 | SCREW IH PANM | | 4 | |
| 535 07 53-01 | 535075301 | PLATE | | 1 | |
| 535 03 49-01 | 535034901 | ENGINE | | 1 | |
| 535 09 84-08 | 535098408 | RIVET | | 4 | |
| 535 09 84-12 | 535098412 | RIVET | | 4 | |
| 535 05 55-01 | 535055501 | CABLE | | 1 | |
| 535 04 20-01 | 535042001 | NUT | | 2 | |
| 535 03 95-01 | 535039501 | CLIP | | 1 | |
| 535 03 61-01 | 535036101 | SCREW | | 4 | |

B *compl 535 09 88-01
*compl 535 09 88-02 (US)

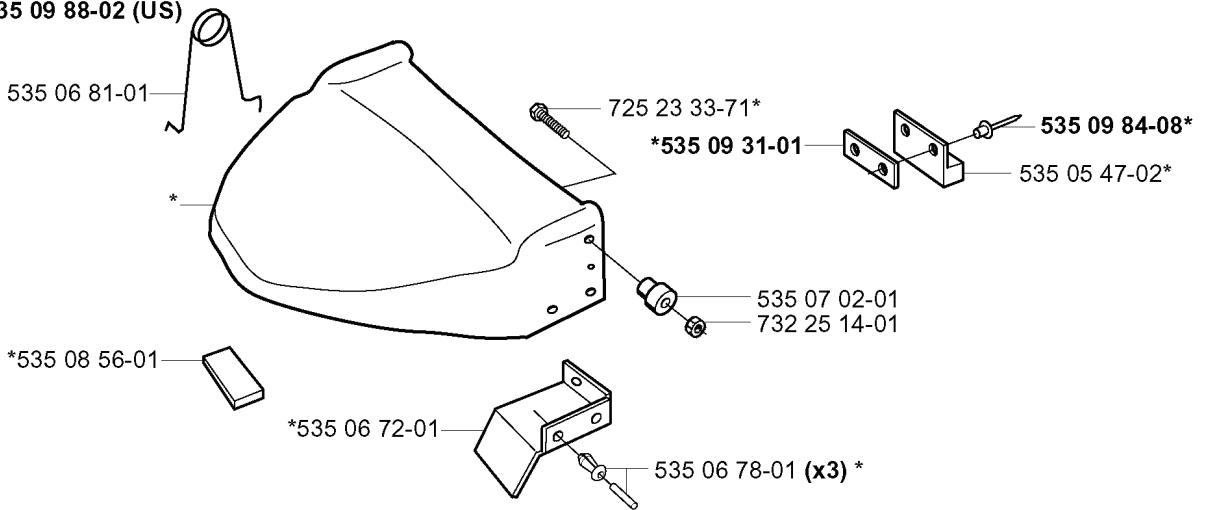

| REF. | PART NO. | DESCRIPTION | REMARK | QTY. | KIT |
|--------------|-----------|---------------------|--------|------|-----|
| 535 09 88-01 | 535098801 | COVER | | 1 | |
| 535 09 88-02 | 535098802 | COVER | US | 1 | |
| 535 06 81-01 | 535068101 | SPRING | | 1 | |
| 535 08 56-01 | 535085601 | BUMPER | | 0 | |
| 535 06 72-01 | 535067201 | COVER | | 1 | |
| 535 06 78-01 | 535067801 | RIVET | | 3 | |
| 732 25 14-01 | 732251401 | HEXAGON LOCKING NUT | | 1 | |
| 535 07 02-01 | 535070201 | BUSHING | | 1 | |
| 535 09 31-01 | 535093101 | WASHER | | 1 | |
| 725 23 33-71 | 725233371 | SCREW EHHM | | 1 | |
| 535 05 47-02 | 535054702 | MAGNET | | 1 | |
| 535 09 84-08 | 535098408 | RIVET | | 1 | |