

AUTOMOWER G1 2000 2000-02

SPARE PARTS LIST

A

*compl 535 08 73-01
*compl 535 08 73-02 (US)

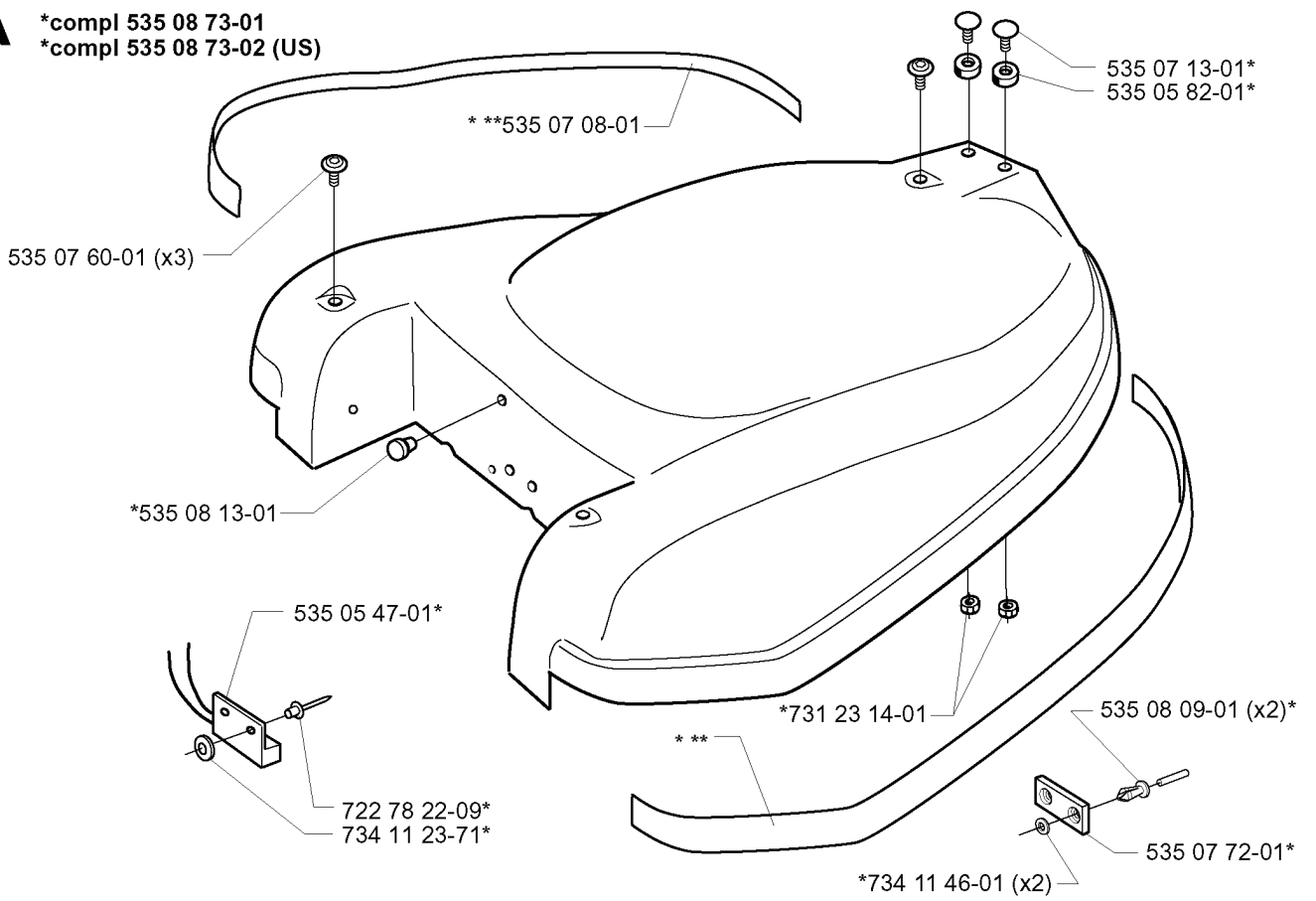

REF.	PART NO.	DESCRIPTION	REMARK	QTY.	KIT
535 08 73-01	535087301	COVER		1	
535 08 73-02	535087302	COVER	US	1	
535 07 60-01	535076001	SCREW		3	
535 08 13-01	535081301	BUFFER		1	
535 05 47-01	535054701	SWITCH		1	
722 78 22-09	722782209	BLIND RIVET		1	
734 11 23-71	734112371	WASHER		1	
731 23 14-01	731231401	HEXAGON NUT		1	
535 07 08-01	535070801	TAPE		1	
535 07 13-01	535071301	SCREW		1	
535 05 82-01	535058201	WASHER		1	
535 08 09-01	535080901	RIVET		2	
535 07 72-01	535077201	RAIL		1	
734 11 46-01	734114601	WASHER		2	

C

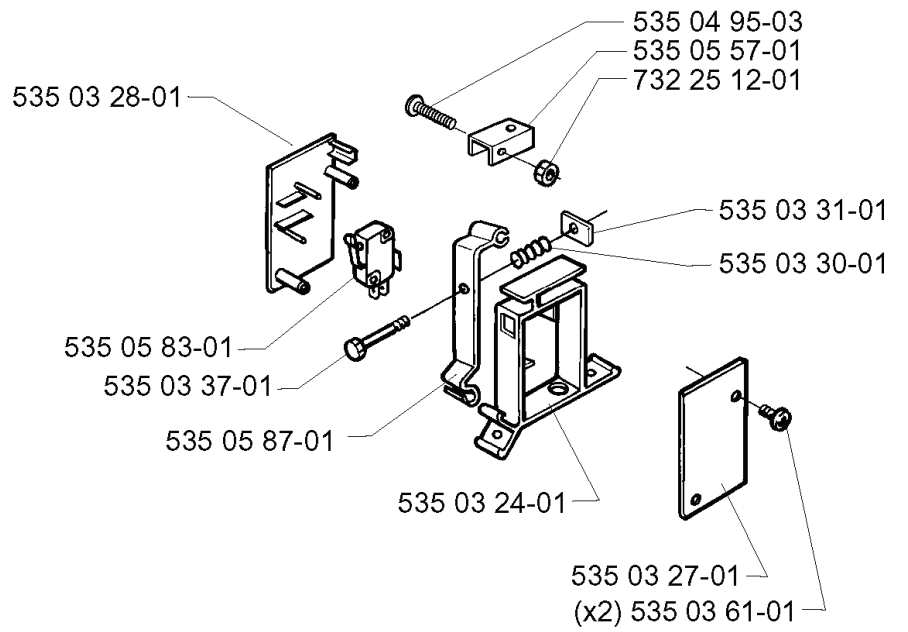
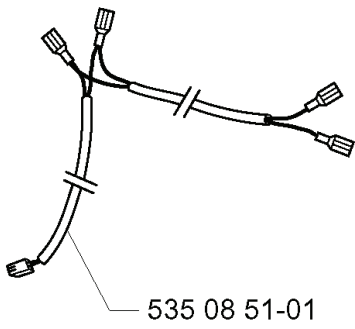

REF.	PART NO.	DESCRIPTION	REMARK	QTY.	KIT
535 08 51-01	535085101	CABLE ASSY		1	
535 03 28-01	535032801	COVER		1	
535 05 83-01	535058301	SWITCH		1	
535 03 37-01	535033701	SCREW		1	
535 05 87-01	535058701	LEVER		1	
535 03 24-01	535032401	BRACKET		1	
535 03 27-01	535032701	COVER		1	
535 03 61-01	535036101	SCREW		2	
535 03 30-01	535033001	SPRING		1	
535 03 31-01	535033101	NUT		1	
732 25 12-01	732251201	HEXAGON LOCKING NUT		1	
535 05 57-01	535055701	BRACKET		1	
535 04 95-03	535049503	SCREW IH PANM		1	

K

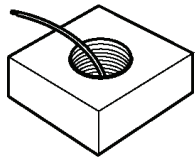

535 04 16-01

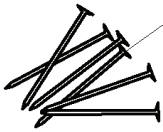

535 08 88-01

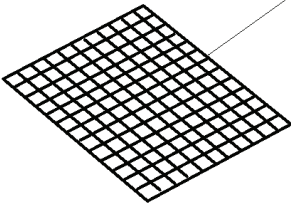

535 08 79-01

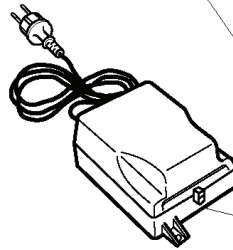

535 07 89 -01

535 07 85-01 **EU**
535 07 86-01 **GB**
535 07 87-01 **CH**
535 07 88-01 **US**



535 05 05-01

REF.	PART NO.	DESCRIPTION	REMARK	QTY.	KIT
535 04 16-01	535041601	WIRE		1	
535 08 88-01	535088801	PIN RETAINING SCREW		1	
535 08 79-01	535087901	SCREEN		1	
535 05 05-01	535050501	STAPLE		1	
535 07 88-01	535078801	TRANSFORMER	US	1	
535 07 87-01	535078701	TRANSFORMER	CH	1	
535 07 86-01	535078601	TRANSFORMER	GB	1	
535 07 85-01	535078501	TRANSFORMER	EU	1	
535 07 89-01	535078901	WIRE		1	

B

*compl 535 08 63-01
*compl 535 08 63-02 (US)

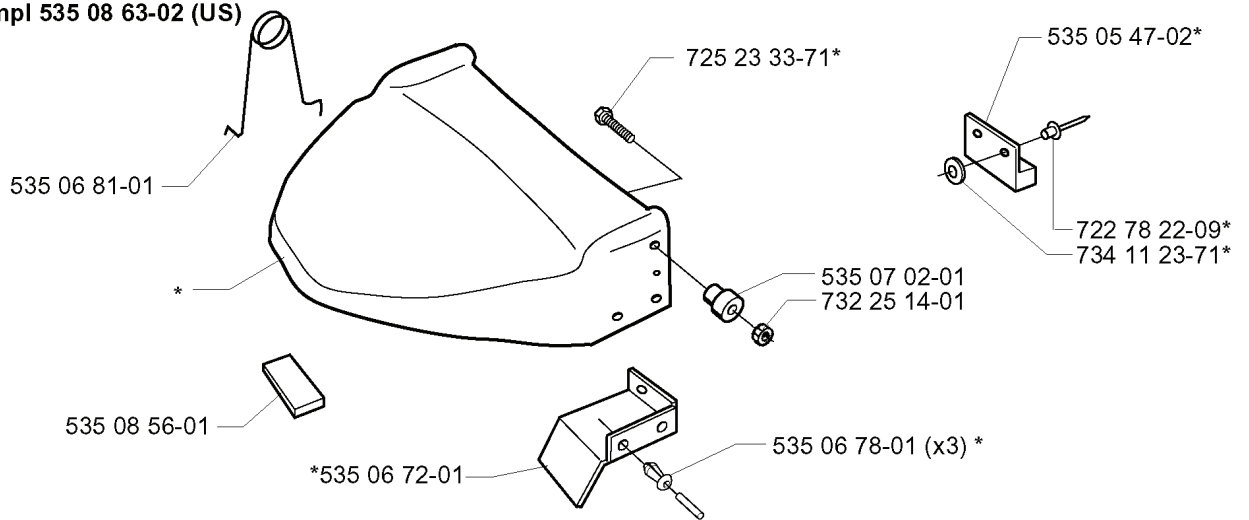

REF.	PART NO.	DESCRIPTION	REMARK	QTY.	KIT
535 08 63-01	535086301	COVER		1	
535 08 63-02	535086302	COVER	US	1	
535 06 81-01	535068101	SPRING		1	
535 08 56-01	535085601	BUMPER		1	
535 06 72-01	535067201	COVER		1	
535 06 78-01	535067801	RIVET		3	
732 25 14-01	732251401	HEXAGON LOCKING NUT		1	
535 07 02-01	535070201	BUSHING		1	
725 23 33-71	725233371	SCREW EHHM		1	
535 05 47-02	535054702	MAGNET		1	
722 78 22-09	722782209	BLIND RIVET		1	
734 11 23-71	734112371	WASHER		1	

REF.	PART NO.	DESCRIPTION	REMARK	QTY.	KIT
535 09 10-01	535091001	CHARGING STATION		1	
535 07 71-01	535077101	WASHER		1	
535 06 56-01	535065601	SWITCH		1	
535 07 83-01	535078301	COVER		1	
535 07 82-01	535078201	PLATE		1	
724 11 95-01	724119501	SCREW CRPANM		2	
535 08 12-01	535081201	TRIGGER		8	
535 08 96-01	535089601	CONNECTION		1	
731 23 09-01	731230901	HEXAGON NUT		2	
535 07 84-01	535078401	DECAL		1	
729 57 09-01	729570901	SCREW CCRPANT		4	
535 03 39-02	535033902	SCREW IHANM		1	
535 05 32-01	535053201	PLATE		1	
506 55 07-01	506550701	INSULATING WASHER		1	
506 55 06-01	506550601	PLUG		1	
535 05 33-01	535053301	BRACKET		1	
535 06 16-01	535061601	CABLE		1	
732 25 14-01	732251401	HEXAGON LOCKING NUT		1	
535 08 17-01	535081701	PRINTED CIRCUIT CARD		1	
535 06 73-01	535067301	SPACER		4	
535 03 39-01	535033901	SCREW IHANM		4	
734 11 46-01	734114601	WASHER		4	
731 23 14-01	731231401	HEXAGON NUT		4	
535 08 97-01	535089701	CABLE ASSY		1	
535 05 34-01	535053401	COVER		1	
535 08 14-01	535081401	WASHER		1	
535 07 60-01	535076001	SCREW		1	

E

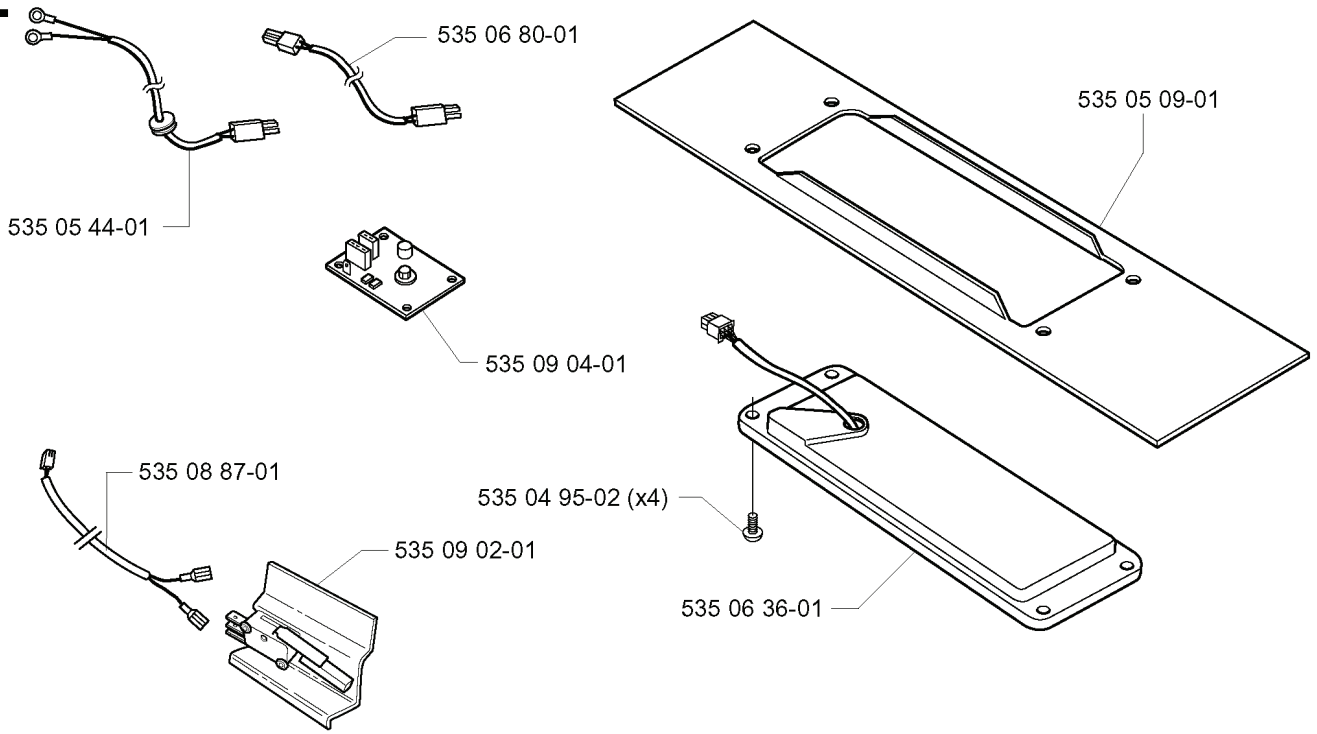

REF.	PART NO.	DESCRIPTION	REMARK	QTY.	KIT
535 06 80-01	535068001	CABLE		1	
535 05 44-01	535054401	CABLE		1	
535 09 04-01	535090401	PRINTED CIRCUIT CARD		1	
535 08 87-01	535088701	CABLE ASSY		1	
535 09 02-01	535090201	SWITCH		1	
535 04 95-02	535049502	SCREW IH PANM		4	
535 06 36-01	535063601	BATTERY		1	
535 05 09-01	535050901	COVER		1	

J

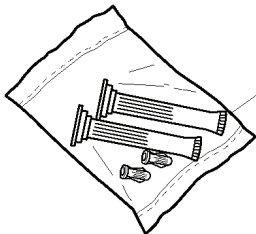
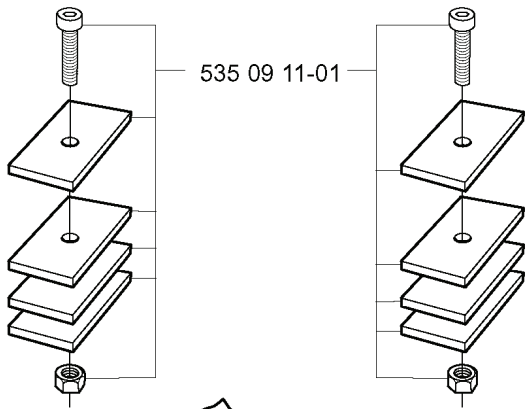

REF.	PART NO.	DESCRIPTION	REMARK	QTY.	KIT
535 09 11-01	535091101	COUNTERWEIGHT		1	
535 04 43-01	535044301	COUPLER		1	
505 69 99-90	505699990	BAG		1	

D

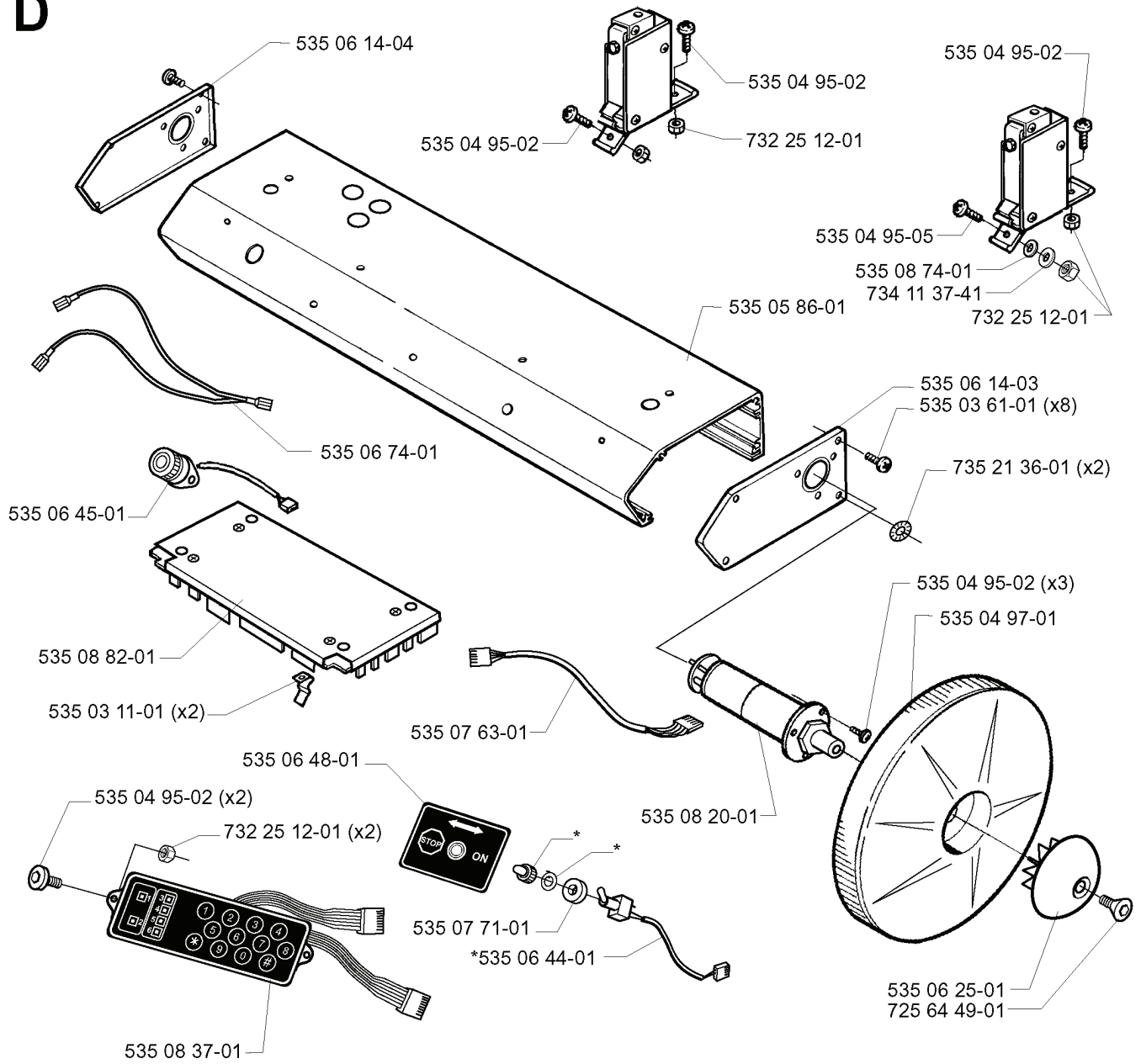

REF.	PART NO.	DESCRIPTION	REMARK	QTY.	KIT
535 06 14-04	535061404	END		1	
535 06 45-01	535064501	BUZZER		1	
535 08 82-01	535088201	PRINTED CIRCUIT CARD		1	
535 03 11-01	535031101	SPRING		2	
535 08 37-01	535083701	KEYBOARD		1	
535 04 95-02	535049502	SCREW IH PANM		1	
535 06 74-01	535067401	CABLE		1	
535 07 63-01	535076301	CABLE ASSY		1	
535 06 48-01	535064801	DECAL		1	
535 07 71-01	535077101	WASHER		1	
535 06 44-01	535064401	SWITCH		1	
535 08 20-01	535082001	ENGINE	Motor w/o gearbox 535 10 66-01	1	
725 64 49-01	725644901	SCREW IHCSFM		1	
535 06 25-01	535062501	WASHER		1	
535 04 97-01	535049701	GEAR WHEEL		1	
735 21 36-01	735213601	LOCKWASHER		2	
535 03 61-01	535036101	SCREW		8	
535 06 14-03	535061403	END		1	
732 25 12-01	732251201	HEXAGON LOCKING NUT		1	
535 05 86-01	535058601	BOX		1	
734 11 37-41	734113741	WASHER		1	
535 08 74-01	535087401	WASHER		1	
535 04 95-05	535049505	SCREW IH PANM		1	

G

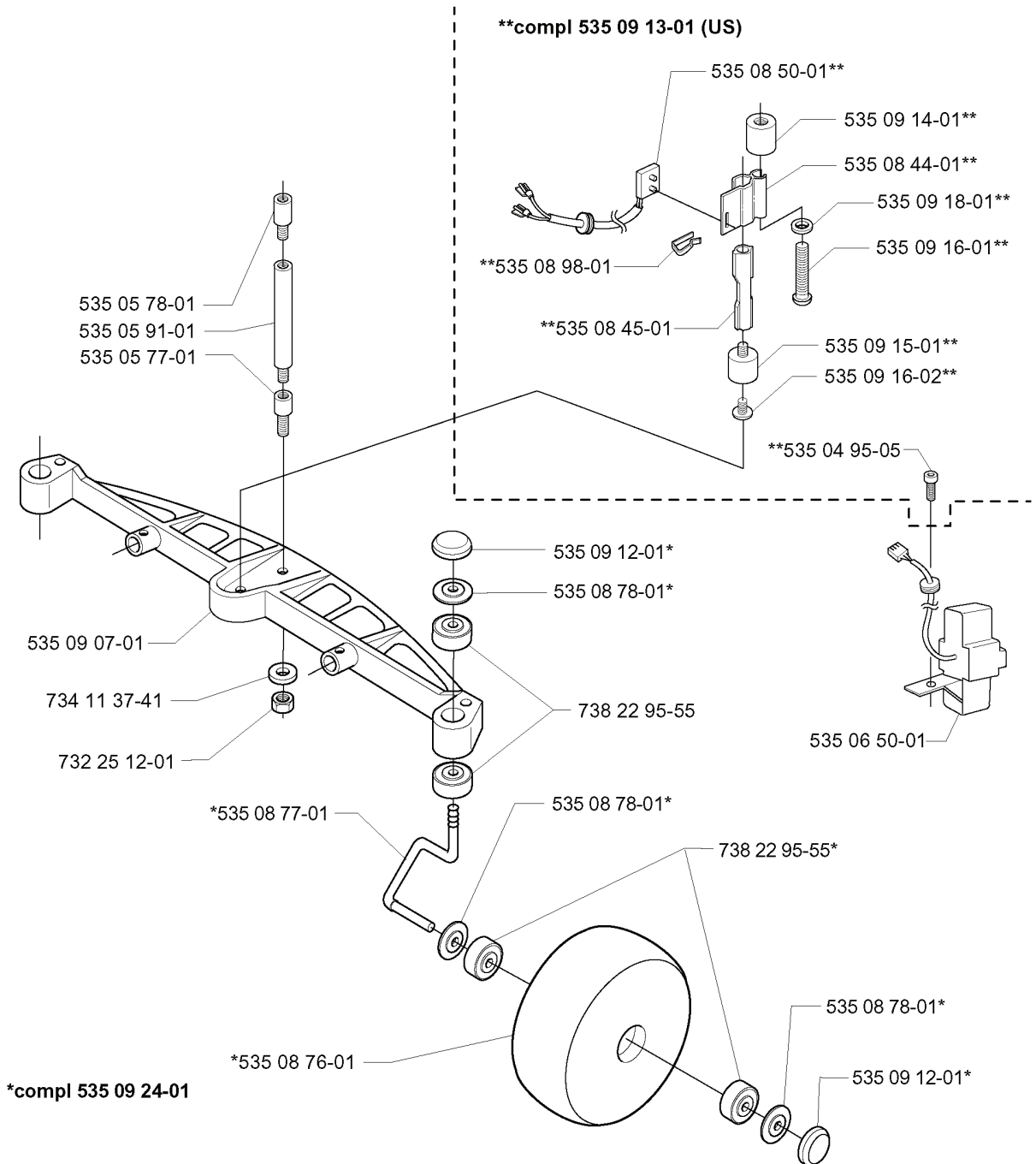

REF.	PART NO.	DESCRIPTION	REMARK	QTY.	KIT
535 05 78-01	535057801	ABSORBER		1	
535 05 91-01	535059101	BRACKET		1	
535 05 77-01	535057701	ABSORBER		1	
535 09 07-01	535090701	BRACKET		1	
734 11 37-41	734113741	WASHER		1	
732 25 12-01	732251201	HEXAGON LOCKING NUT		1	
535 08 77-01	535087701	SPINDLE SHAFT		1	
535 09 24-01	535092401	WHEEL		1	
535 08 76-01	535087601	WHEEL		1	
535 08 78-01	535087801	COVER WASHER		1	
738 22 95-55	738229555	BALL BEARING		1	
535 09 12-01	535091201	WASHER		1	
535 08 45-01	535084501	ROD		1	
535 08 98-01	535089801	CLIP		1	
535 09 13-01	535091301	LIFT SENSOR	US	1	
535 08 50-01	535085001	CABLE ASSY		1	
535 09 14-01	535091401	DAMPER		1	
535 08 44-01	535084401	BRACKET		1	
535 09 18-01	535091801	WASHER		1	
535 09 16-01	535091601	SCREW		1	
535 09 15-01	535091501	BUMPER		1	
535 09 16-02	535091602	SCREW		1	
535 04 95-05	535049505	SCREW IH PANM		1	
535 06 50-01	535065001	SENSOR		1	

F

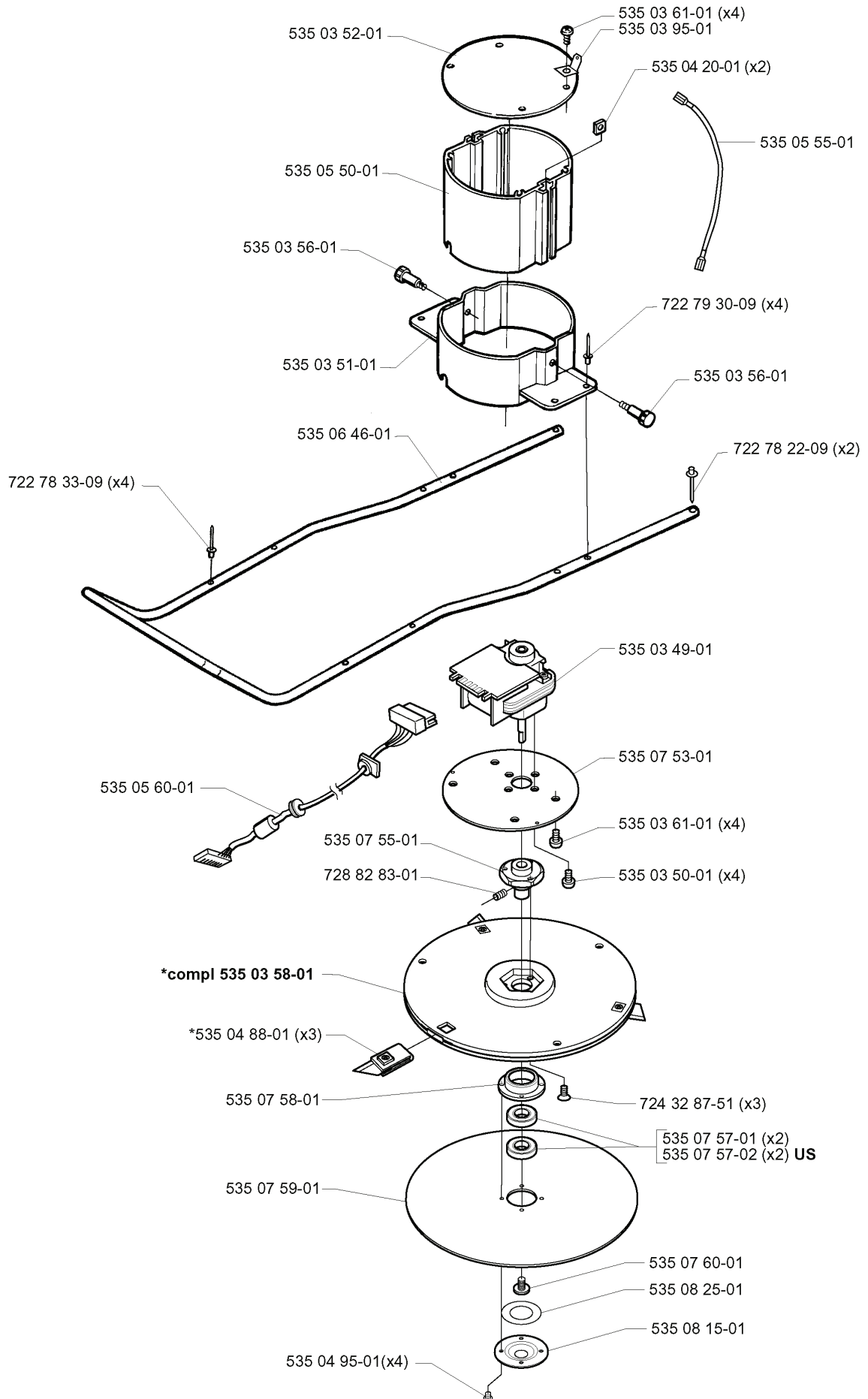

REF.	PART NO.	DESCRIPTION	REMARK	QTY.	KIT
535 03 52-01	535035201	COVER		1	
535 05 50-01	535055001	PIPE		1	
535 03 56-01	535035601	KNOB		1	
535 03 51-01	535035101	PIPE		1	
535 06 46-01	535064601	PIPE		1	
722 78 33-09	722783309	BLIND RIVET		4	
535 05 60-01	535056001	CABLE		1	
535 07 55-01	535075501	HUB		1	
728 82 83-01	728828301	SCREW IHSETM		1	
535 03 58-01	535035801	BLADE DISC. CPL.		1	
535 04 88-01	535048801	BLADE SET		3	
535 07 58-01	535075801	HOLDER		1	
535 07 59-01	535075901	SKID PLATE		1	
535 04 95-01	535049501	SCREW IH PANM		4	
535 08 15-01	535081501	COVER WASHER		1	
535 08 25-01	535082501	GASKET		1	
535 07 60-01	535076001	SCREW		1	
535 07 57-02	535075702	BALL BEARING	US	2	
535 07 57-01	593080801	BALL BEARING	Tube 50 pcs	1	
535 07 57-01	535075701	BALL BEARING		2	
724 32 87-51	724328751	SCREW CRCSFM		3	
535 03 50-01	535035001	SCREW		4	
535 07 53-01	535075301	PLATE		1	
535 03 49-01	535034901	ENGINE		1	
722 78 22-09	722782209	BLIND RIVET		2	
722 79 30-09	722793009	BLIND RIVET		4	
535 05 55-01	535055501	CABLE		1	
535 04 20-01	535042001	NUT		2	
535 03 95-01	535039501	CLIP		1	
535 03 61-01	535036101	SCREW		4	