

AUTOMOWER G2 2003 2003-08

SPARE PARTS LIST

C * compl 535 13 29-01 EU
* compl 535 13 30-01 US

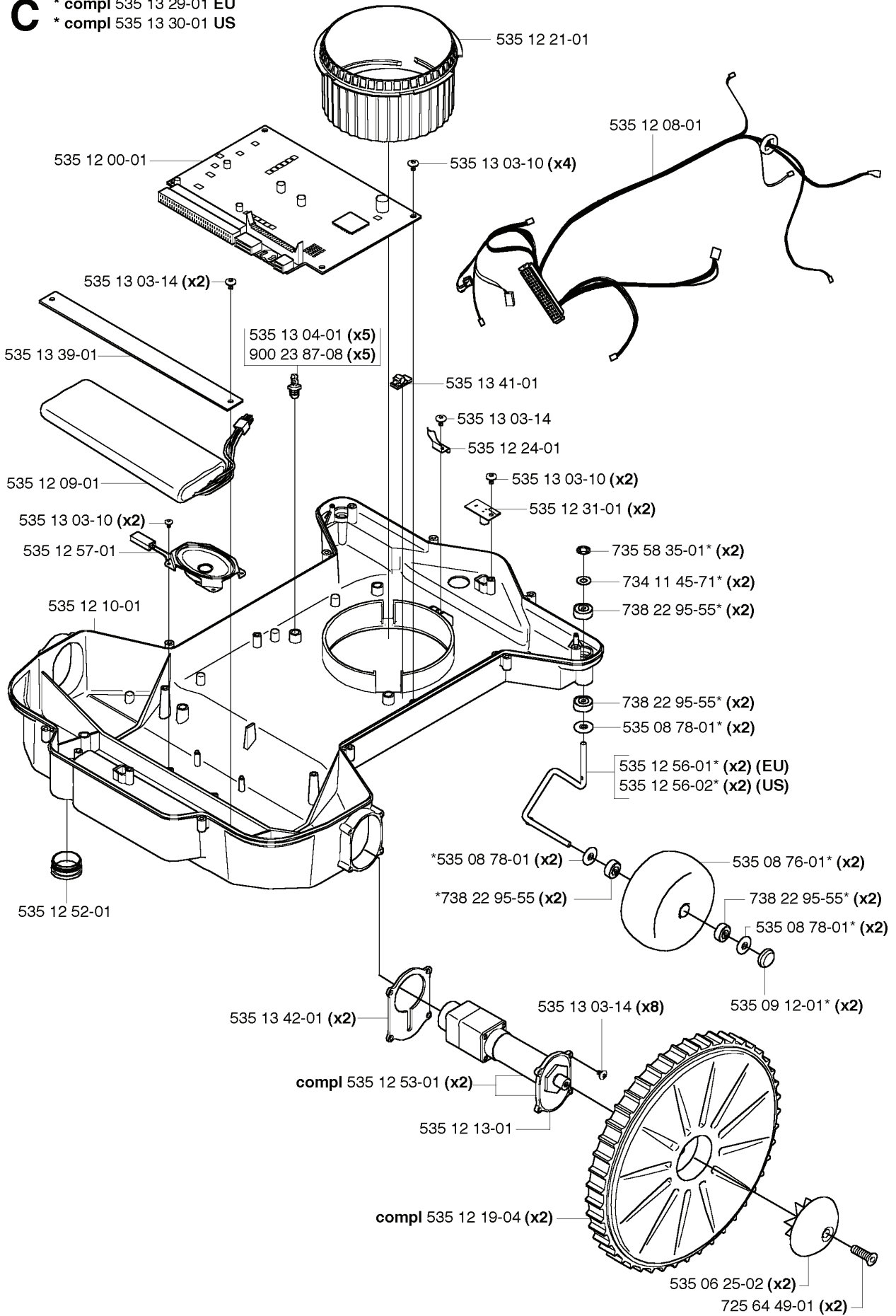

REF.	PART NO.	DESCRIPTION	REMARK	QTY.	KIT
535 13 29-01	535132901	KIT	EU	1	
535 13 30-01	535133001	KIT	US	1	
535 12 00-01	535120001	CONTROL BOARD		1	
535 13 03-14	535130314	SCREW ITPANT		2	
535 13 39-01	535133901	RETAINER		1	
535 12 09-01	535120901	BATTERY		1	
535 13 03-10	535130310	SCREW ITPANT		2	
535 12 57-01	535125701	LOUD SPEAKER		1	
535 12 10-01	535121001	CHASSIS		1	
535 12 52-01	535125201	PLUG		1	
535 13 42-01	535134201	GASKET		2	
535 12 53-01	535125301	MOTOR		2	
535 12 13-01	535121301	GABLE		1	
535 12 19-04	535121904	GEAR WHEEL ASSY		2	
535 06 25-02	535062502	WASHER		2	
725 64 49-01	725644901	SCREW IHCSFM		2	
535 08 78-01	535087801	COVER WASHER		2	
900 23 87-08	900238708	TIE WRAP		5	
535 13 04-01	535130401	ANCHOR		5	
535 12 21-01	535122101	NUT		1	
535 13 41-01	535134101	CABLE HOLDER		1	
535 12 24-01	535122401	LOCKING SPRING		1	
535 12 31-01	535123101	SENSOR CARD		2	
735 58 35-01	735583501	WASHER		2	
734 11 45-71	734114571	WASHER		2	
738 22 95-55	738229555	BALL BEARING		2	
535 12 56-01	535125601	SPINDLE SHAFT	EU	2	
535 12 56-02	535125602	SPINDLE SHAFT	US	2	
535 08 76-01	535087601	WHEEL		2	
535 09 12-01	535091201	WASHER		2	
535 12 08-01	535120801	WIRING		1	

E compl 535 12 75-01 (EU)
compl 535 12 75-02 (US)

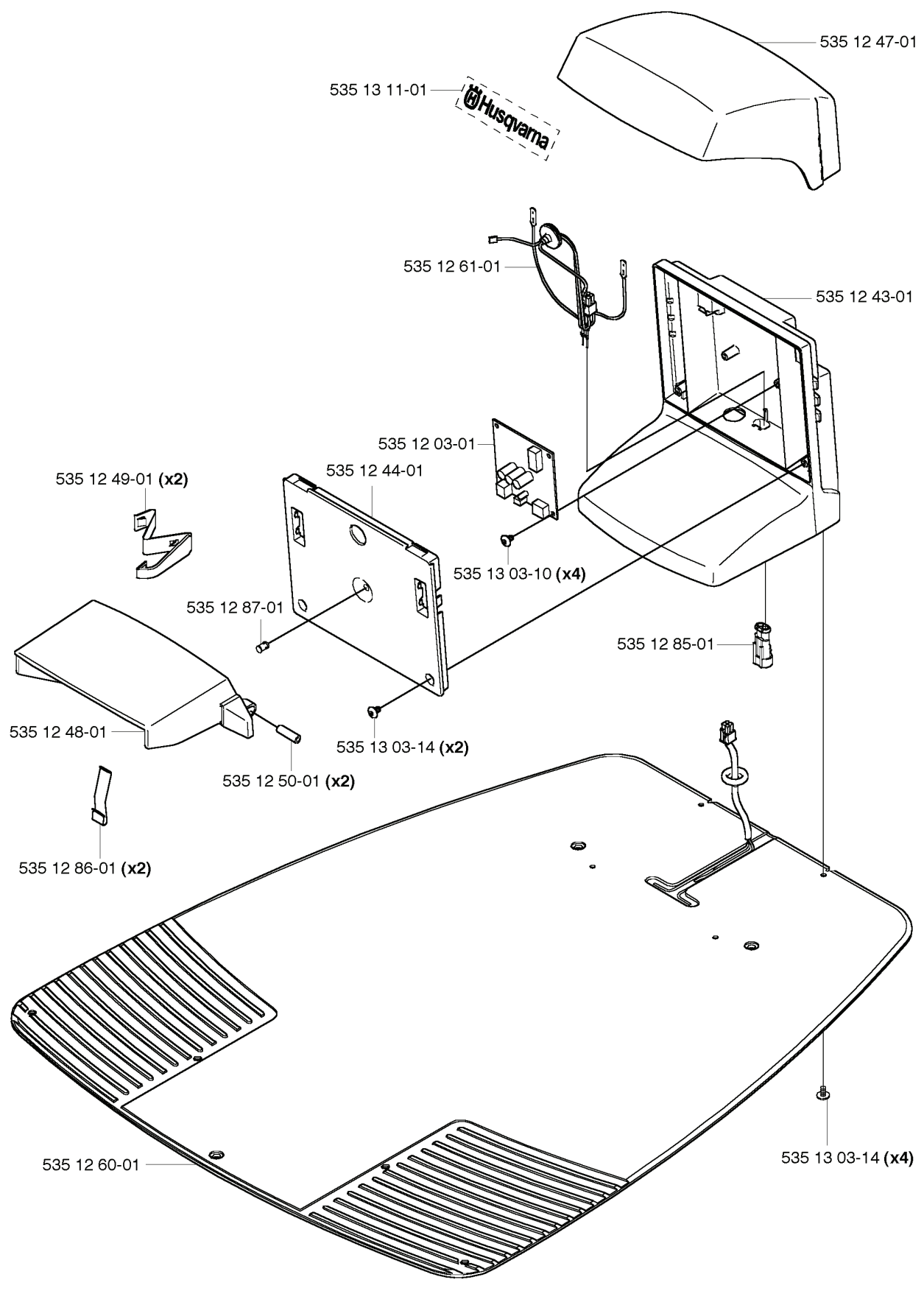

REF.	PART NO.	DESCRIPTION	REMARK	QTY.	KIT
535 12 75-01	535127501	CHARGING STATION	EU	1	
535 12 75-02	535127502	CHARGING STATION	US	1	
535 13 11-01	535131101	LABEL		1	
535 12 61-01	535126101	WIRING		1	
535 12 03-01	535120301	GENERATOR CARD		1	
535 12 44-01	535124401	HUB CAP		1	
535 12 87-01	535128701	DIODE LENS		1	
535 12 49-01	535124901	CHARGING PLATE		2	
535 12 48-01	535124801	RETAINER		1	
535 12 86-01	535128601	SPRING PLATE		2	
535 12 60-01	535126001	FRAME PLATE		1	
535 12 50-01	535125001	PEN		2	
535 13 03-14	535130314	SCREW IXPANT		2	
535 13 03-10	535130310	SCREW IXPANT		4	
535 12 85-01	535128501	CONTACT		1	
535 12 43-01	535124301	BODY		1	
535 12 47-01	535124701	COVER		1	

F

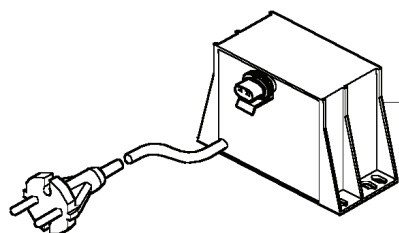

535 12 37-01 (EU)
535 12 37-02 (UK+IRL)
535 12 37-03 (CH)
535 12 37-04 (US)



535 05 05-01 (x100)



535 12 73-01 (20m)



535 08 89-01 (x6)

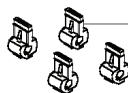

535 12 90-01 (x4)

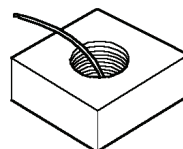

535 13 17-01 (250m)



535 09 87-01 (x9)



535 13 36-01



535 13 37-01 (x2)



535 13 16-01

REF.	PART NO.	DESCRIPTION	REMARK	QTY.	KIT
535 12 37-01	535123701	POWER UNIT	EU	1	
535 12 37-02	535123702	POWER UNIT	UK+IRL	1	
535 12 37-03	535123703	POWER UNIT	CH	1	
535 12 37-04	535123704	TRANSFORMER	US	1	
535 12 73-01	535127301	CABLE	20M	1	
535 12 90-01	535129001	CONNECTOR		4	
535 09 87-01	535098701	BLADE SET		9	
535 13 37-01	535133701	COUPLER		2	
535 13 16-01	535131601	LABEL		1	
535 13 36-01	535133601	MEASURING TAPE		1	
535 13 17-01	535131701	WIRE	250M	1	
535 08 89-01	535088901	STAPLE		6	
535 05 05-01	535050501	STAPLE		100	

B

* compl 535 13 31-01

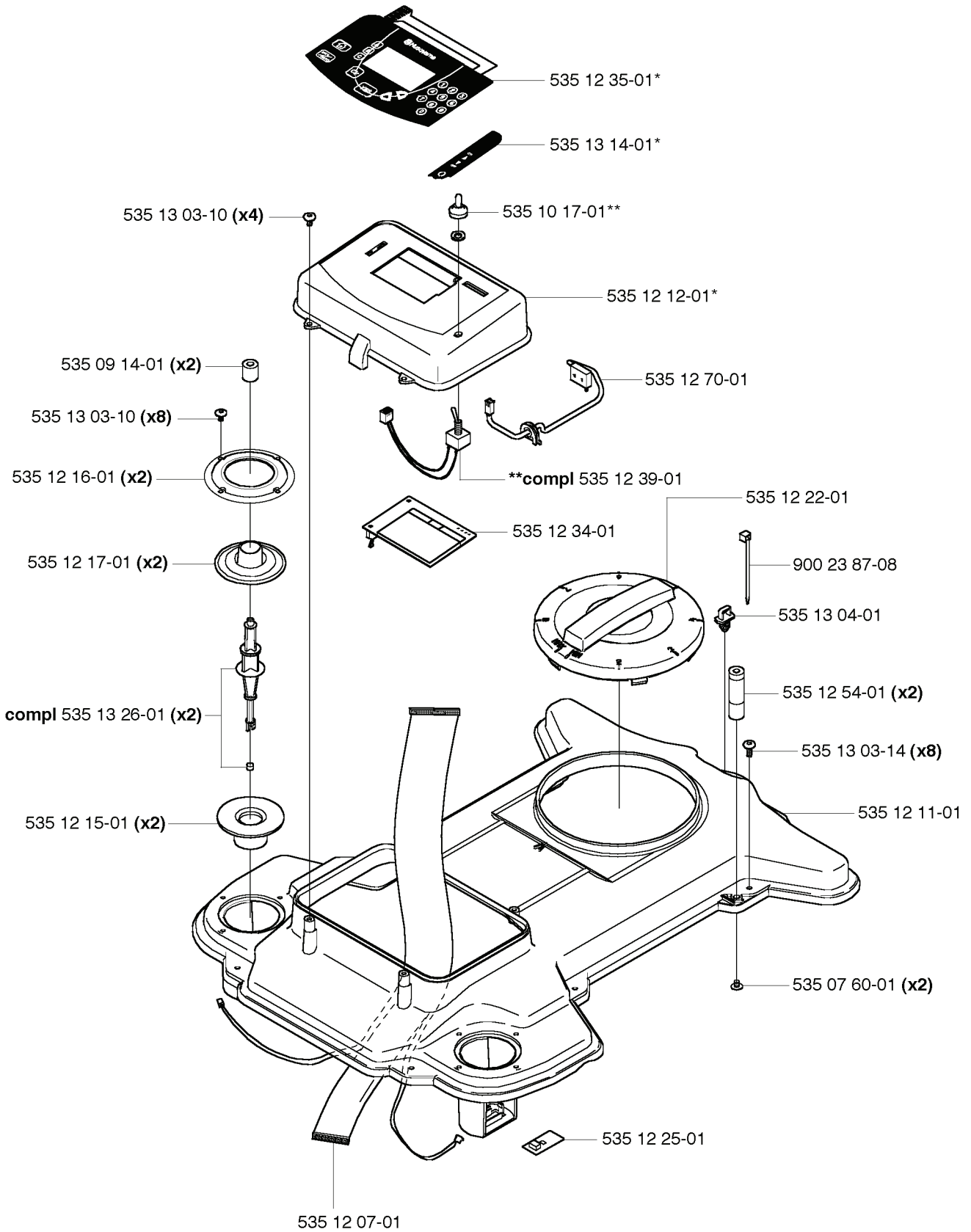

REF.	PART NO.	DESCRIPTION	REMARK	QTY.	KIT
535 13 03-10	535130310	SCREW ITPANT		4	
535 09 14-01	535091401	DAMPER		2	
535 12 16-01	535121601	RING FASTENER		2	
535 12 17-01	535121701	RUBBER GAITERS		2	
535 13 26-01	535132601	COLUMN		2	
535 12 15-01	535121501	DEFLECTION LIMITER		2	
535 12 07-01	535120701	WIRING		1	
535 12 25-01	535122501	SENSOR CARD		1	
535 07 60-01	535076001	SCREW		2	
535 12 11-01	535121101	CHASSIS		1	
535 13 03-14	535130314	SCREW ITPANT		8	
535 12 54-01	535125401	COLUMN		2	
535 13 04-01	535130401	ANCHOR		1	
900 23 87-08	900238708	TIE WRAP		1	
535 12 22-01	535122201	STEERING WHEEL		1	
535 12 34-01	535123401	DISPLAY		1	
535 12 39-01	535123901	MAIN SWITCH		1	
535 12 70-01	535127001	SWITCH		1	
535 12 12-01	535121201	DISPLAY COVER		1	
535 10 17-01	535101701	SWITCH		1	
535 13 14-01	535131401	LABEL		1	
535 12 35-01	535123501	KEYBOARD		1	
535 13 31-01	535133101	KIT		1	

A compl 535 12 96-01

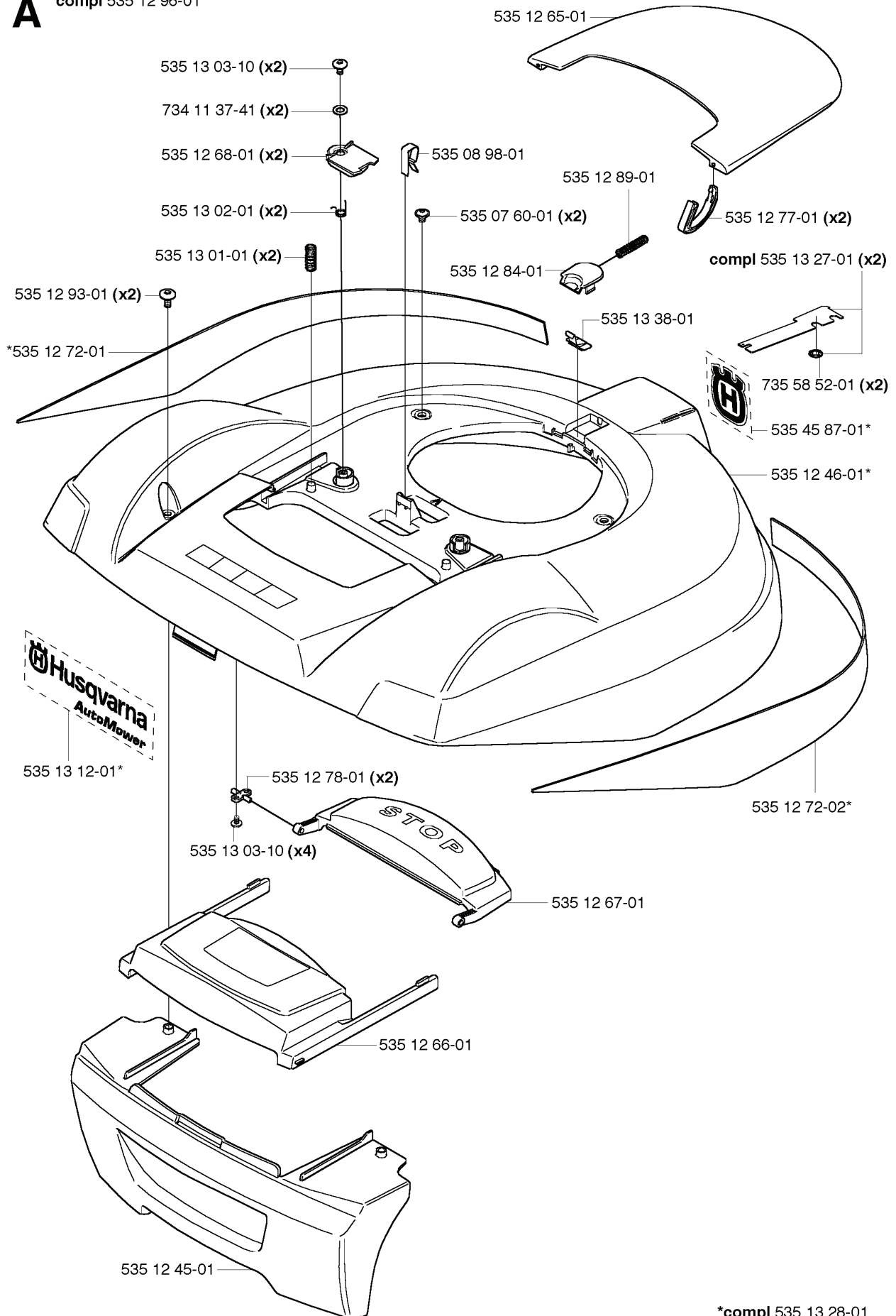

REF.	PART NO.	DESCRIPTION	REMARK	QTY.	KIT
535 12 96-01	535129601	MAIN BODY		1	
734 11 37-41	734113741	WASHER		2	
535 12 68-01	535126801	CLAMP		2	
535 13 02-01	535130201	TORSION SPRING		2	
535 13 01-01	535130101	SPRING		2	
535 12 93-01	535129301	SCREW IH PANM		2	
535 12 72-01	535127201	PROJECTIVE LIST		1	
535 13 12-01	535131201	LABEL		1	
535 12 78-01	535127801	SHAFT		2	
535 13 03-10	535130310	SCREW ITPANT		4	
535 12 45-01	535124501	MAIN BODY		1	
535 12 66-01	535126601	COVER		1	
535 12 67-01	535126701	SWITCH		1	
535 12 84-01	535128401	LOCKING BOLT		1	
535 07 60-01	535076001	SCREW		2	
535 08 98-01	535089801	CLIP		1	
535 12 65-01	535126501	COVER		1	
535 12 89-01	535128901	SPRING		1	
535 13 38-01	535133801	SPRING PLATE		1	
535 12 72-02	535127202	PROJECTIVE LIST		1	
535 12 46-01	535124601	MAIN BODY		1	
535 45 87-01	535458701	LABEL		1	
735 58 52-01	735585201	WASHER		2	
535 13 27-01	535132701	KIT		2	
535 12 77-01	535127701	PIVOT		2	

G

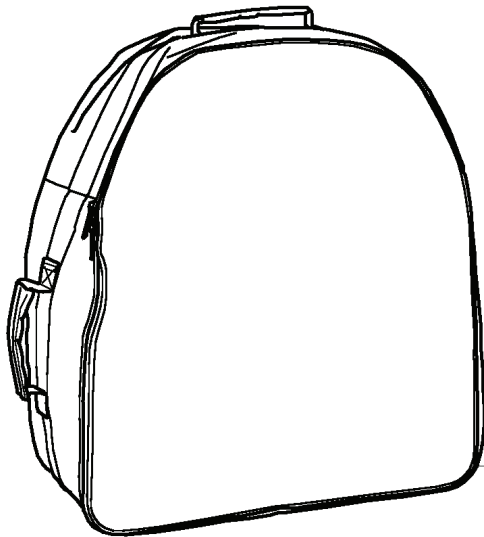

505 69 99-90

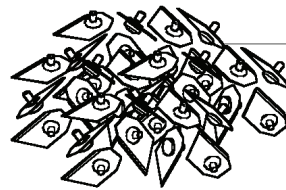

535 10 64-01 (x30)

REF.	PART NO.	DESCRIPTION	REMARK	QTY.	KIT
505 69 99-90	505699990	BAG		1	
535 10 64-01	535106401	BLADE SET		30	

D

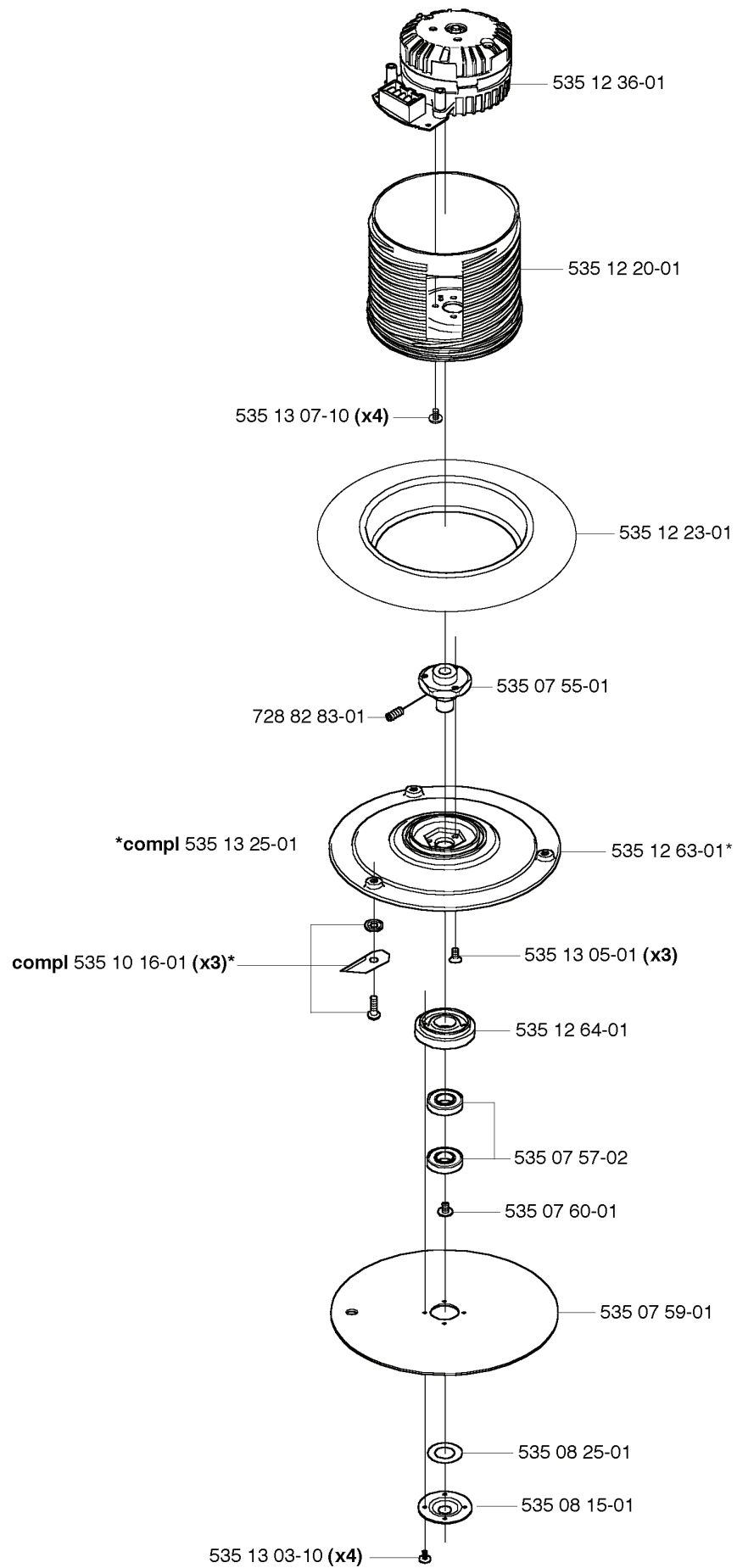

REF.	PART NO.	DESCRIPTION	REMARK	QTY.	KIT
535 13 07-10	535130710	SCREW		4	
728 82 83-01	728828301	SCREW IHSETM		1	
535 13 25-01	535132501	KNIFE DISK		1	
535 10 16-01	535101601	BLADE		3	
535 13 03-10	535130310	SCREW ITXPANT		4	
535 08 15-01	535081501	COVER WASHER		1	
535 08 25-01	535082501	GASKET		1	
535 07 59-01	535075901	SKID PLATE		1	
535 07 60-01	535076001	SCREW		1	
535 07 57-02	593080801	BALL BEARING	Tube 50 pcs	1	
535 07 57-02	535075702	BALL BEARING		1	
535 12 64-01	535126401	HOUSING		1	
535 13 05-01	535130501	SCREW		3	
535 12 63-01	535126301	CUTTING DISC		1	
535 07 55-01	535075501	HUB		1	
535 12 23-01	535122301	RUBBER GAITERS		1	
535 12 20-01	535122001	MOTOR BOWL		1	
535 12 36-01	535123601	MOTOR ASSY		1	