

UTOMOWER G2 2006 GENERATION 2 2006

SPARE PARTS LIST

H Accessories
 Zubehöre
 Accessoires
 Accesorios
 Tillbehör

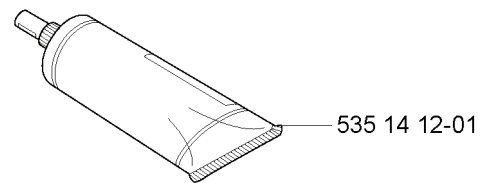
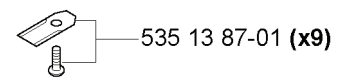
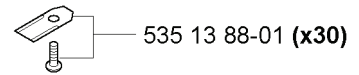

CD Autocheck 2006 535 14 27-04

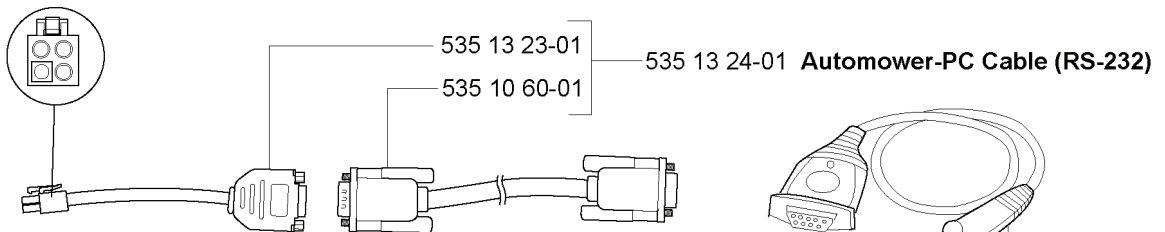
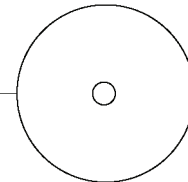

USB V-COM adapter 544 08 50-01

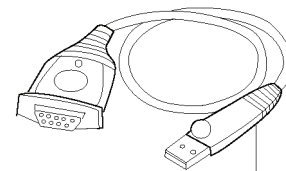

REF.	PART NO.	DESCRIPTION	REMARK	QTY.	KIT
505 69 99-91	505699991	BAG		1	
535 14 27-04	535142704	DEALER CD	CD AUTOCHECK 2006	1	
535 13 23-01	535132301	WIRING		1	
535 10 60-01	535106001	CABLE		1	
535 13 24-01	535132401	CABLE ASSY	AUTOMOWER-PC CABLE (RS-232)	1	
544 08 50-01	544085001	ADAPTER	USB V-COM ADAPTER	1	
535 14 12-01	535141201	SEALING		1	
535 13 87-01	535138701	BLADE		9	
535 13 88-01	535138801	KIT		30	

E compl 544 25 33-01

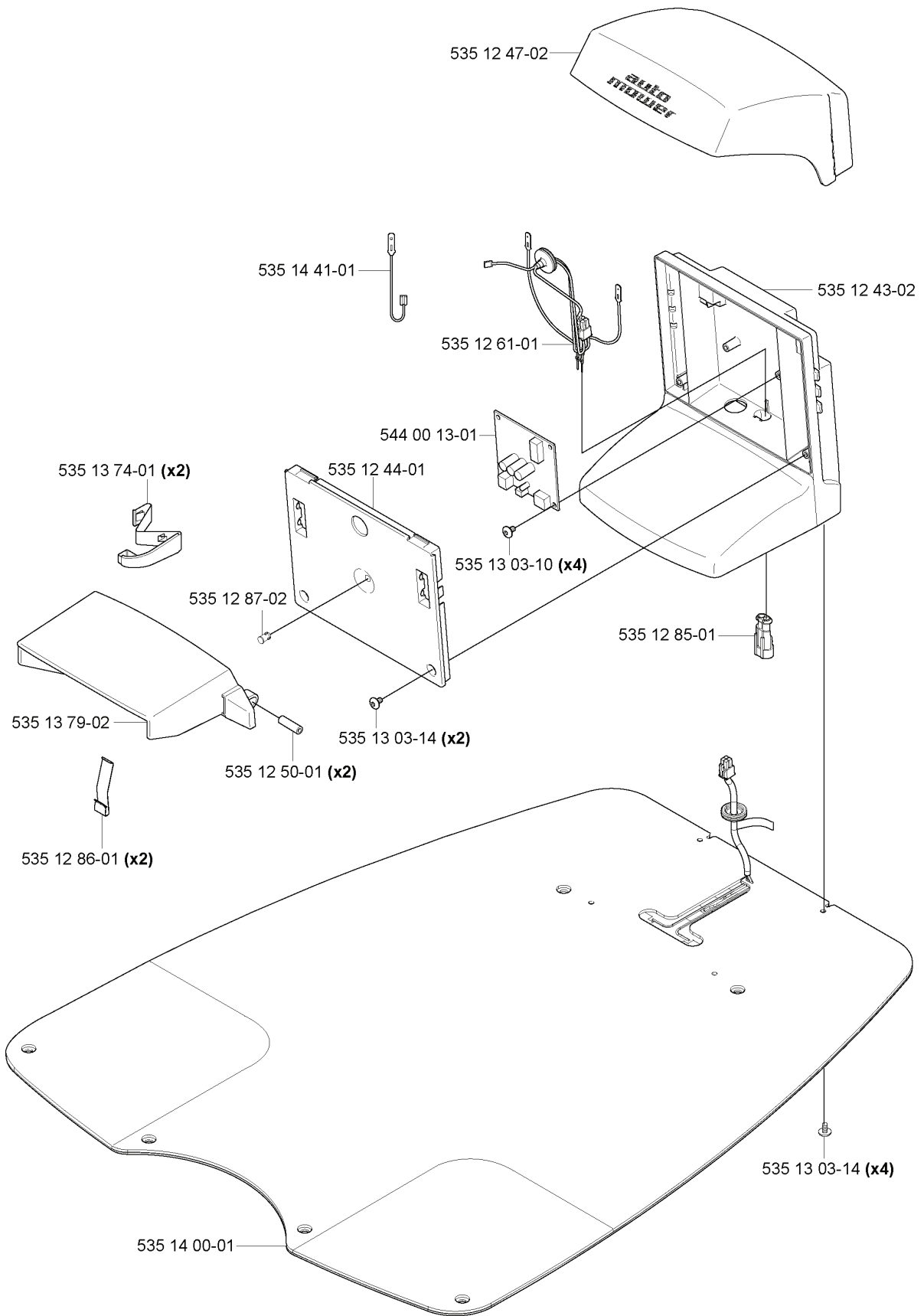

REF.	PART NO.	DESCRIPTION	REMARK	QTY.	KIT
544 25 33-01	544253301	CHARGING STATION		1	
535 12 47-02	535124702	COVER		1	
535 14 41-01	535144101	CABLE		1	
535 12 61-01	535126101	WIRING		1	
544 00 13-01	544001301	PRINTED CIRCUIT CARD		1	
535 12 44-01	535124401	HUB CAP		1	
535 12 87-02	535128702	DIODE LENS		1	
535 13 74-01	535137401	CHARGING PLATE		2	
535 13 79-02	535137902	RETAINER		1	
535 12 86-01	535128601	SPRING PLATE		2	
535 14 00-01	535140001	FRAME PLATE		1	
535 12 50-01	535125001	PEN		2	
535 13 03-10	535130310	SCREW ITPANT		4	
535 12 85-01	535128501	CONTACT		1	
535 13 03-14	535130314	SCREW ITPANT		4	
535 12 43-02	535124302	BODY		1	

G

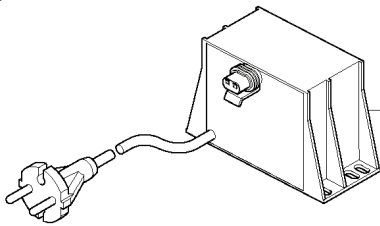

- 535 12 37-01 (EU)
- 535 12 37-02 (UK+IRL)
- 535 12 37-03 (CH)
- 535 12 37-04 (US)



535 05 05-01 (x100)

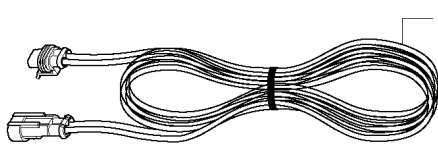

535 12 73-01 (20m)



535 08 89-01 (x6)



535 12 90-01

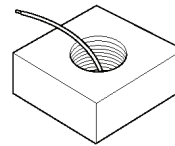

535 13 17-01 (250m)



544 17 75-01



535 13 37-01



535 13 16-01

REF.	PART NO.	DESCRIPTION	REMARK	QTY.	KIT
535 12 37-01	535123701	POWER UNIT	EU	1	
535 12 37-02	535123702	POWER UNIT	UK+IRL	1	
535 12 37-03	535123703	POWER UNIT	CH	1	
535 12 37-04	535123704	TRANSFORMER	US	1	
535 12 73-01	535127301	CABLE	20M	1	
535 12 90-01	535129001	CONNECTOR		1	
535 13 37-01	535133701	COUPLER		1	
535 13 16-01	535131601	LABEL		1	
544 17 75-01	544177501	MEASURING TAPE		1	
535 13 17-01	535131701	WIRE	250M	1	
535 08 89-01	535088901	STAPLE		6	
535 05 05-01	535050501	STAPLE		100	

B

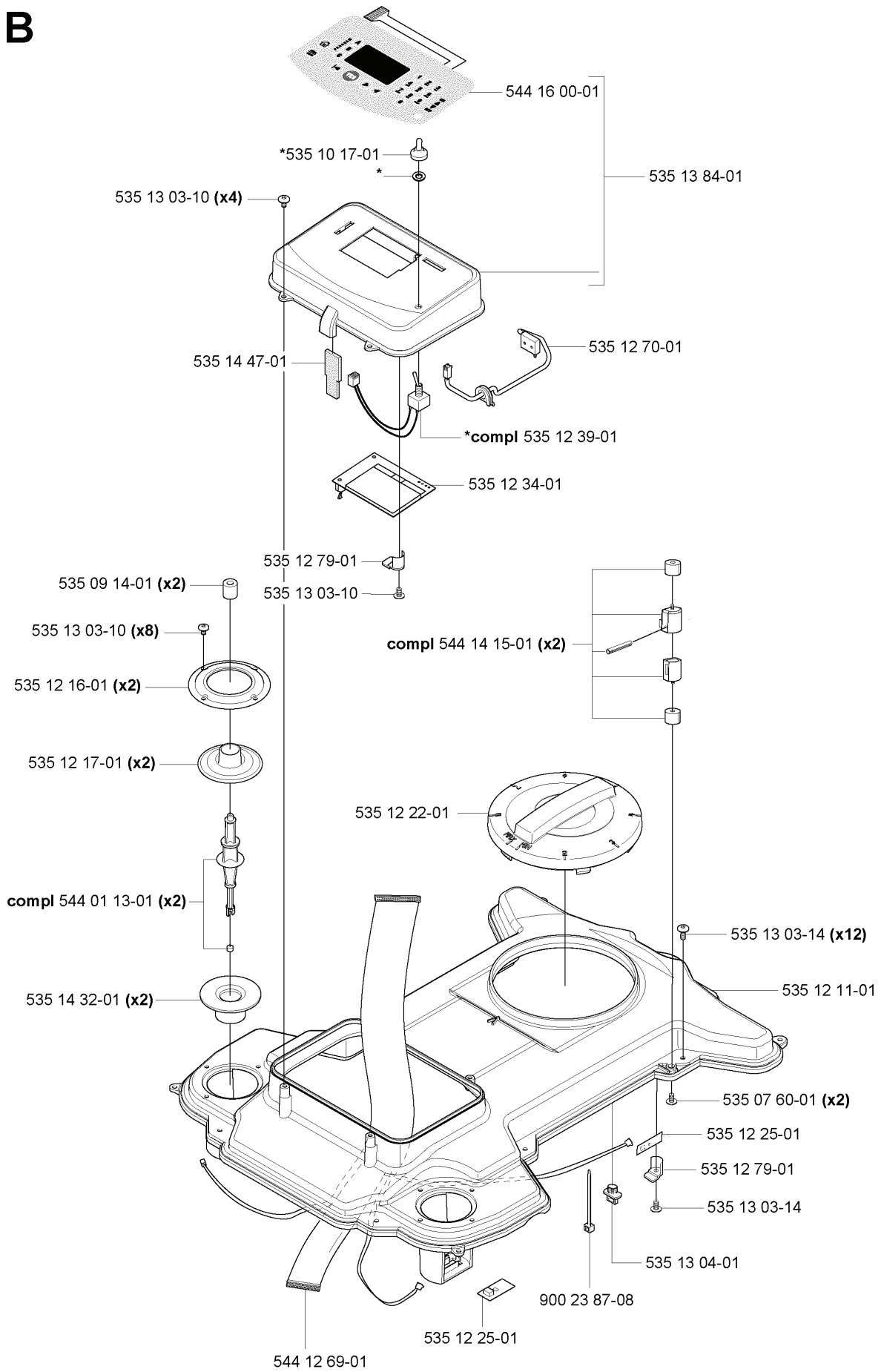

REF.	PART NO.	DESCRIPTION	REMARK	QTY.	KIT
535 10 17-01	535101701	SWITCH		1	
535 14 47-01	535144701	FILTER		1	
535 09 14-01	535091401	DAMPER		2	
535 13 03-10	535130310	SCREW ITXPANT		8	
535 12 16-01	535121601	RING FASTENER		2	
535 12 17-01	535121701	RUBBER GAITERS		2	
544 01 13-01	544011301	COLUMN		2	
535 14 32-01	535143201	DEFLECTION LIMITER		2	
544 12 69-01	544126901	WIRING ASSY		1	
535 12 25-01	535122501	SENSOR CARD		1	
900 23 87-08	900238708	TIE WRAP		1	
535 13 04-01	535130401	ANCHOR		1	
535 13 03-14	535130314	SCREW ITXPANT		1	
535 07 60-01	535076001	SCREW		2	
535 12 11-01	535121101	CHASSIS		1	
535 12 22-01	535122201	STEERING WHEEL		1	
544 14 15-01	544141501	SENSOR		2	
535 12 79-01	535127901	BRACKET		1	
535 12 34-01	535123401	DISPLAY		1	
535 12 39-01	535123901	MAIN SWITCH		1	
535 12 70-01	535127001	SWITCH		1	
535 13 84-01	535138401	CONTROL PANEL		1	
544 16 00-01	544160001	KEYBOARD		1	

D

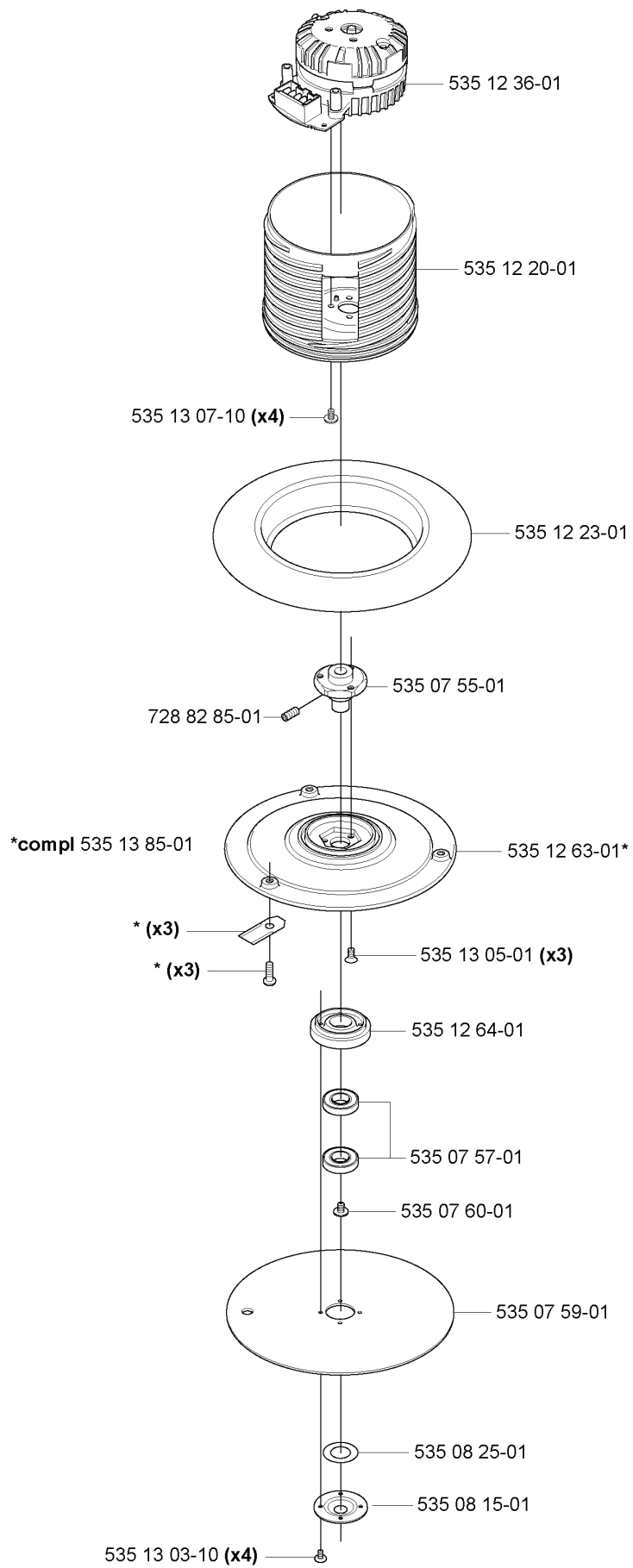

REF.	PART NO.	DESCRIPTION	REMARK	QTY.	KIT
535 13 07-10	535130710	SCREW		4	
728 82 85-01	728828501	SCREW IHSETM		1	
535 13 85-01	535138501	KIT		1	
535 13 03-10	535130310	SCREW ITXPANT		4	
535 08 15-01	535081501	COVER WASHER		1	
535 08 25-01	535082501	GASKET		1	
535 07 59-01	535075901	SKID PLATE		1	
535 07 60-01	535076001	SCREW		1	
535 07 57-01	593080801	BALL BEARING	Tube 50 pcs	1	
535 07 57-01	535075701	BALL BEARING		1	
535 12 64-01	535126401	HOUSING		1	
535 13 05-01	535130501	SCREW		3	
535 12 63-01	535126301	CUTTING DISC		1	
535 07 55-01	535075501	HUB		1	
535 12 23-01	535122301	RUBBER GAITERS		1	
535 12 20-01	535122001	MOTOR BOWL		1	
535 12 36-01	535123601	MOTOR ASSY		1	

C

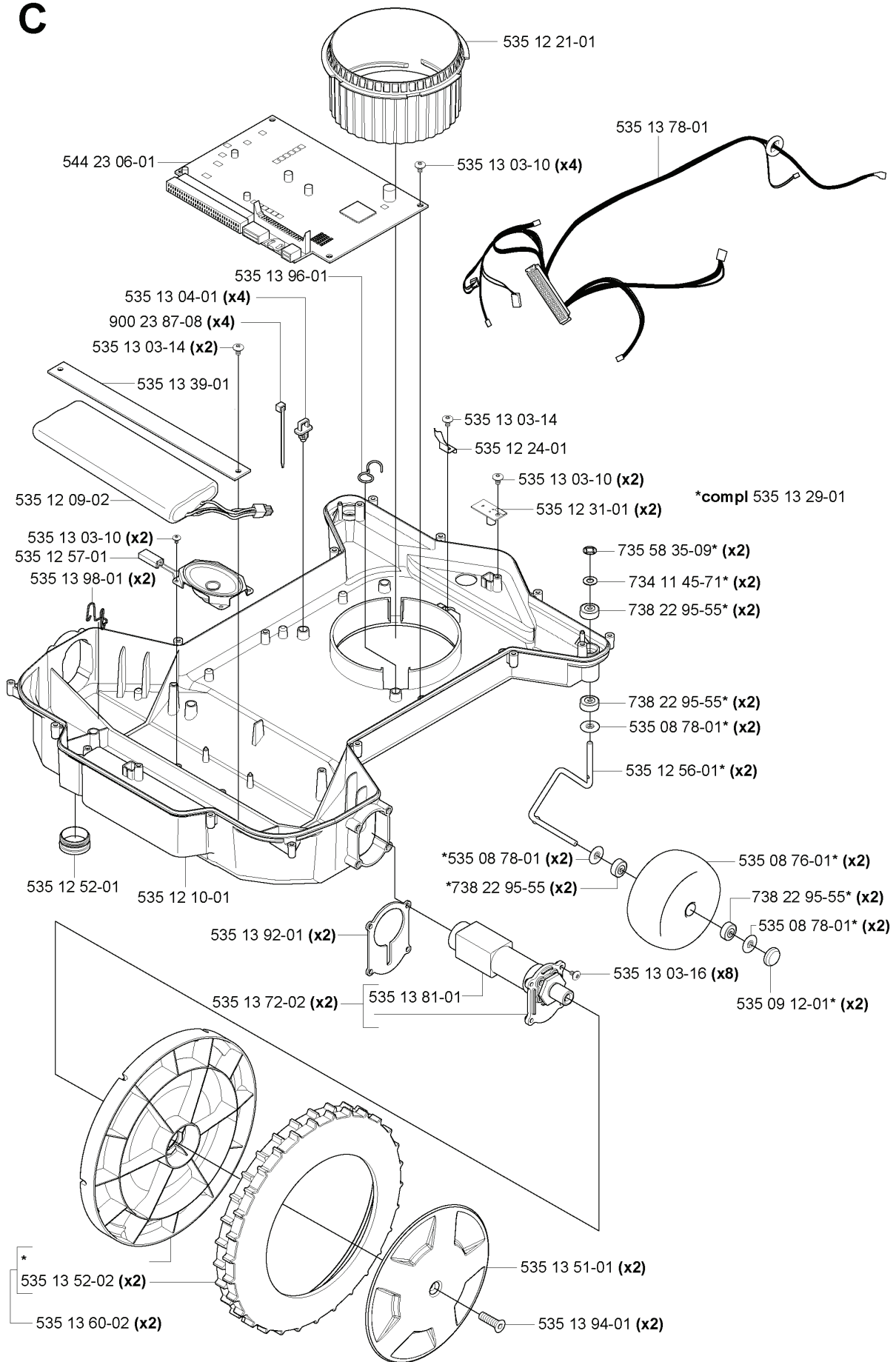

REF.	PART NO.	DESCRIPTION	REMARK	QTY.	KIT
544 23 06-01	544230601	PRINTED CIRCUIT CARD		1	
535 13 96-01	535139601	CABLE HOLDER		1	
535 13 04-01	535130401	ANCHOR		4	
900 23 87-08	900238708	TIE WRAP		4	
535 13 39-01	535133901	RETAINER		1	
535 12 09-02	535120902	BATTERY		1	
535 12 57-01	535125701	LOUD SPEAKER		1	
535 13 98-01	535139801	CABLE HOLDER		2	
535 12 52-01	535125201	PLUG		1	
535 12 10-01	535121001	CHASSIS		1	
535 13 92-01	535139201	GASKET		2	
535 13 81-01	535138101	DRIVE MOTOR		1	
535 13 72-02	535137202	MOTOR		2	
535 13 52-02	535135202	TIRE		2	
535 13 60-02	535136002	GEAR WHEEL		2	
535 13 94-01	535139401	SCREW IHCSFM		2	
535 13 51-01	535135101	HUB CAP		2	
535 13 03-16	535130316	SCREW ITXPANT		8	
535 09 12-01	535091201	WASHER		2	
535 08 78-01	535087801	COVER WASHER		2	
535 08 76-01	535087601	WHEEL		2	
738 22 95-55	738229555	BALL BEARING		2	
535 12 56-01	535125601	SPINDLE SHAFT		2	
734 11 45-71	734114571	WASHER		2	
735 58 35-09	735583509	WASHER		2	
535 13 29-01	535132901	KIT		1	
535 12 31-01	535123101	SENSOR CARD		2	
535 12 24-01	535122401	LOCKING SPRING		1	
535 13 03-14	535130314	SCREW ITXPANT		1	
535 13 03-10	535130310	SCREW ITXPANT		4	
535 13 78-01	535137801	WIRING		1	
535 12 21-01	535122101	NUT		1	

F compl 544 25 30-01 (EU)
compl 544 25 30-02 (UK)
compl 544 25 30-03 (CH)
compl 544 25 30-04 (US)

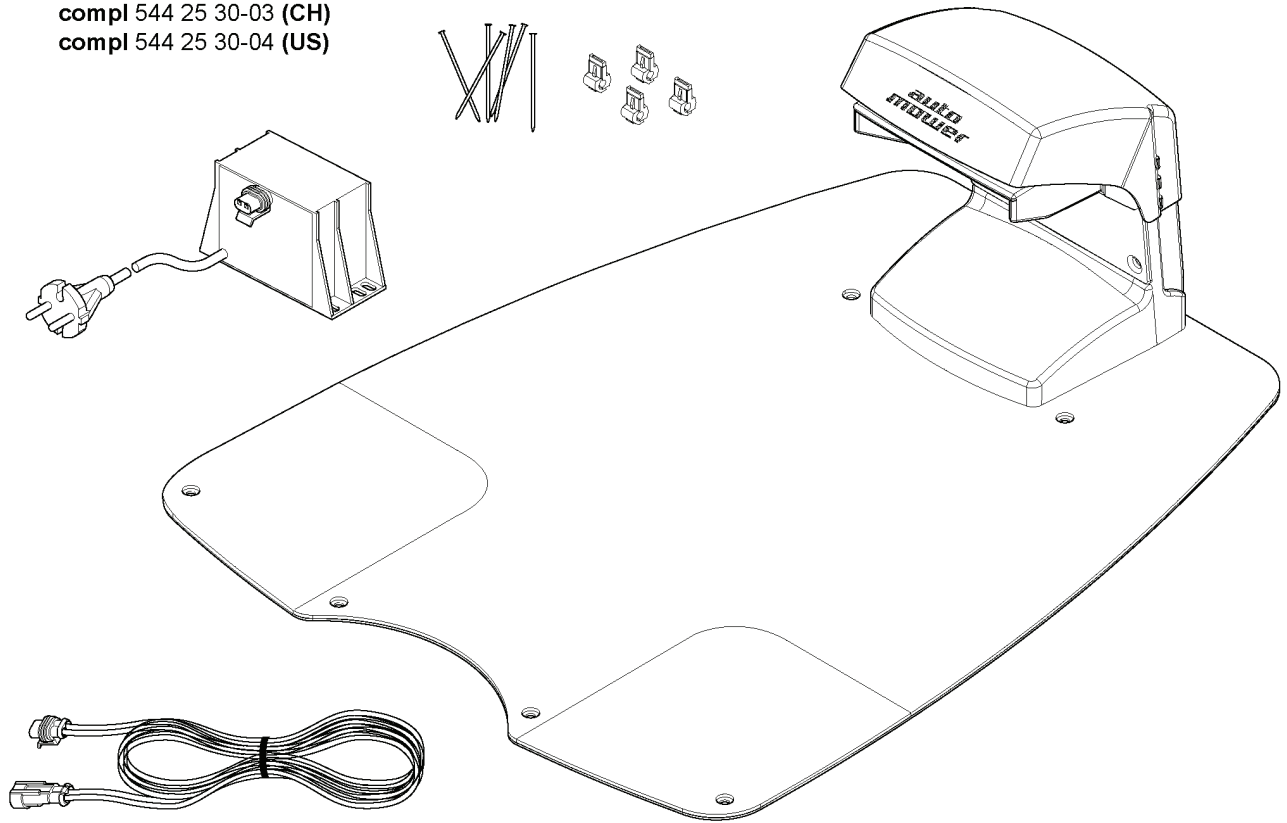

REF.	PART NO.	DESCRIPTION	REMARK	QTY.	KIT
544 25 30-01	544253001	CHARGING STATION	EU	1	
544 25 30-02	544253002	CHARGING STATION	UK	1	
544 25 30-03	544253003	CHARGING STATION	CH	1	
544 25 30-04	544253004	CHARGING STATION	US	1	

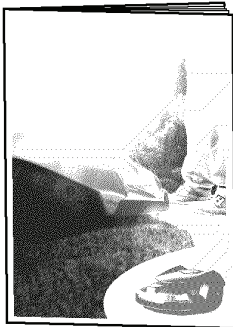

Quick Guide 2006

115 01 69-XX

(US is -26)

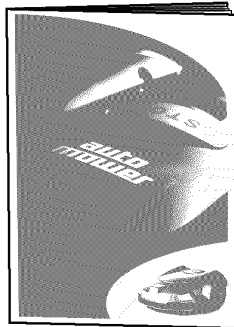

Technical Handbook 2006

115 01 71-XX

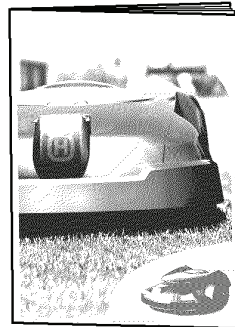

Owners Manual 2006

115 01 70-XX

- 01 Svenska
- 06 Dansk
- 11 Soumi
- 21 Norsk
- 26 GB English
- 31 Francais
- 36 Nederlands
- 41 Italiano
- 46 Espanol
- 51 Deutsch
- 59 Portugues
- 61 Polski
- 90 Czech
- 95 US English

REF.	PART NO.	DESCRIPTION	REMARK	QTY.	KIT
115 01 69-01	115016901	OPERATOR'S MANUAL	QUICK GUIDE 2006 SVENSKA	1	
115 01 70-01	115017001	OPERATOR'S MANUAL	OWNERS MANUAL 2006 SVENSKA	1	
115 01 71-01	115017101	TECHNICAL MANUAL	TECHNICAL HANDBOOK 2006 SVENSKA	1	
115 01 69-06	115016906	OPERATOR'S MANUAL	QUICK GUIDE 2006 DANSK	1	
115 01 70-06	115017006	OPERATOR'S MANUAL	OWNERS MANUAL 2006 DANSK	1	
115 01 71-06	115017106	TECHNICAL MANUAL	TECHNICAL HANDBOOK 2006 DANSK	1	
115 01 69-11	115016911	OPERATOR'S MANUAL	QUICK GUIDE 2006 SOUMI	1	
115 01 70-11	115017011	OPERATOR'S MANUAL	OWNERS MANUAL 2006 SOUMI	1	
115 01 71-11	115017111	TECHNICAL MANUAL	TECHNICAL HANDBOOK 2006 SOUMI	1	
115 01 69-21	115016921	OPERATOR'S MANUAL	QUICK GUIDE 2006 NORSK	1	
115 01 70-21	115017021	OPERATOR'S MANUAL	OWNERS MANUAL 2006 NORSK	1	
115 01 71-21	115017121	TECHNICAL MANUAL	TECHNICAL HANDBOOK 2006 NORSK	1	
115 01 69-26	115016926	OPERATOR'S MANUAL	QUICK GUIDE 2006 GB ENGLISH (US IS -26)	1	
115 01 70-26	115017026	OPERATOR'S MANUAL	OWNERS MANUAL 2006 GB ENGLISH	1	
115 01 71-26	115017126	TECHNICAL MANUAL	TECHNICAL HANDBOOK 2006 GB ENGLISH	1	
115 01 69-31	115016931	OPERATOR'S MANUAL	QUICK GUIDE 2006 FRANCAIS	1	
115 01 70-31	115017031	OPERATOR'S MANUAL	OWNERS MANUAL 2006 FRANCAIS	1	
115 01 71-31	115017131	TECHNICAL MANUAL	TECHNICAL HANDBOOK 2006 FRANCAIS	1	
115 01 69-36	115016936	OPERATOR'S MANUAL	QUICK GUIDE 2006 NEDERLANDS	1	
115 01 70-36	115017036	OPERATOR'S MANUAL	OWNERS MANUAL 2006 NEDERLANDS	1	
115 01 71-36	115017136	TECHNICAL MANUAL	TECHNICAL HANDBOOK 2006 NEDERLANDS	1	
115 01 69-41	115016941	OPERATOR'S MANUAL	QUICK GUIDE 2006 ITALIANO	1	
115 01 70-41	115017041	OPERATOR'S MANUAL	OWNERS MANUAL 2006 ITALIANO	1	
115 01 71-41	115017141	TECHNICAL MANUAL	TECHNICAL HANDBOOK 2006 ITALIANO	1	
115 01 69-46	115016946	OPERATOR'S MANUAL	QUICK GUIDE 2006 ESPANOL	1	
115 01 70-46	115017046	OPERATOR'S MANUAL	OWNERS MANUAL 2006 ESPANOL	1	
115 01 71-46	115017146	TECHNICAL MANUAL	TECHNICAL HANDBOOK 2006 ESPANOL	1	
115 01 69-51	115016951	OPERATOR'S MANUAL	QUICK GUIDE 2006 DEUTSCH	1	
115 01 70-51	115017051	OPERATOR'S MANUAL	OWNERS MANUAL 2006 DEUTSCH	1	
115 01 71-51	115017151	TECHNICAL MANUAL	TECHNICAL HANDBOOK 2006 DEUTSCH	1	
115 01 69-59	115016959	OPERATOR'S MANUAL	QUICK GUIDE 2006 PORTUGUES	1	
115 01 70-59	115017059	OPERATOR'S MANUAL	OWNERS MANUAL 2006 PORTUGUES	1	
115 01 71-59	115017159	TECHNICAL MANUAL	TECHNICAL HANDBOOK 2006 PORTUGUES	1	
115 01 69-61	115016961	OPERATOR'S MANUAL	QUICK GUIDE 2006 POLSKI	1	
115 01 70-61	115017061	OPERATOR'S MANUAL	OWNERS MANUAL 2006 POLSKI	1	
115 01 71-61	115017161	TECHNICAL MANUAL	TECHNICAL HANDBOOK 2006 POLSKI	1	
115 01 69-90	115016990	OPERATOR'S MANUAL	QUICK GUIDE 2006 CZECH	1	
115 01 70-90	115017090	OPERATOR'S MANUAL	OWNERS MANUAL 2006 CZECH	1	
115 01 71-90	115017190	TECHNICAL MANUAL	TECHNICAL HANDBOOK 2006 CZECH	1	
115 01 69-95	115016995	OPERATOR'S MANUAL	QUICK GUIDE 2006 US ENGLISH	1	
115 01 70-95	115017095	OPERATOR'S MANUAL	OWNERS MANUAL 2006 US ENGLISH	1	

REF.	PART NO.	DESCRIPTION	REMARK	QTY.	KIT
115 01 71- 95	115017195	TECHNICAL MANUAL	TECHNICAL HANDBOOK 2006 US ENGLISH	1	

A

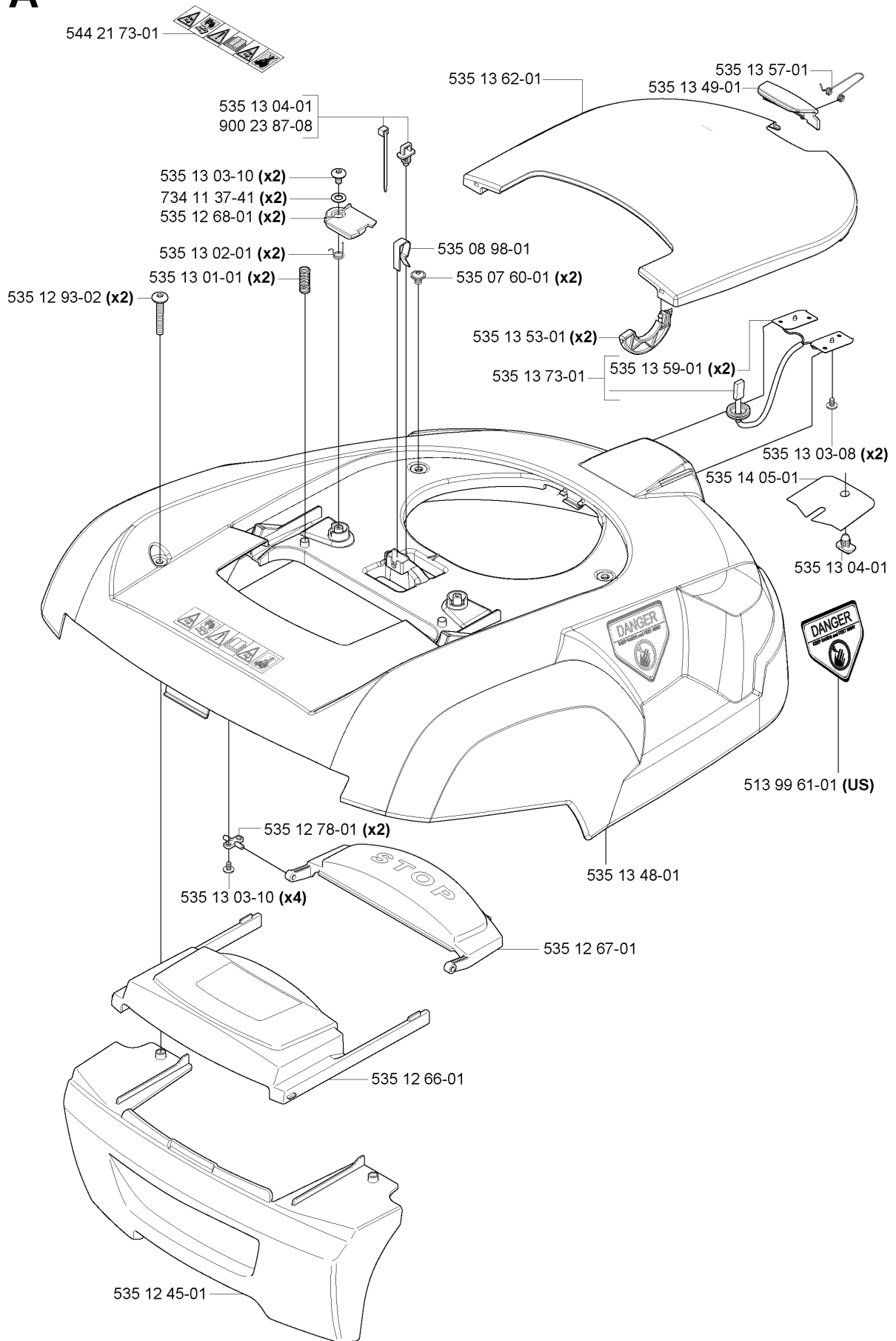

REF.	PART NO.	DESCRIPTION	REMARK	QTY.	KIT
5442173-01	544217301	LABEL		1	
9002387-08	900238708	TIE WRAP		1	
7341137-41	734113741	WASHER		2	
5351268-01	535126801	CLAMP		2	
5351302-01	535130201	TORSION SPRING		2	
5351301-01	535130101	SPRING		2	
5351293-02	535129302	SCREW IH PANM		2	
5351278-01	535127801	SHAFT		2	
5351303-10	535130310	SCREW ITXPANT		4	
5351245-01	535124501	MAIN BODY		1	
5351266-01	535126601	COVER		1	
5351267-01	535126701	SWITCH		1	
5351348-01	535134801	MAIN BODY		1	
5139961-00	513996100	DECAL	US	1	
5351304-01	535130401	ANCHOR		1	
5351405-01	535140501	PROTECTIVE WASHER		1	
5351303-08	535130308	SCREW ITXPANT		2	
5351359-01	535135901	CHARGING PLATE		2	
5351373-01	535137301	WIRING		1	
5351353-01	535135301	PIVOT		2	
5350760-01	535076001	SCREW		2	
5350898-01	535089801	CLIP		1	
5351362-01	535136201	COVER		1	
5351349-01	535134901	LOCK		1	
5351357-01	535135701	TORSION SPRING		1	