

AUTOMOWER G1 2002C 2003-01

SPARE PARTS LIST

A *compl 535 09 77-01

*535 08 55-01 (x2)  **Husqvarna**
Auto Mower 

*535 08 58-01

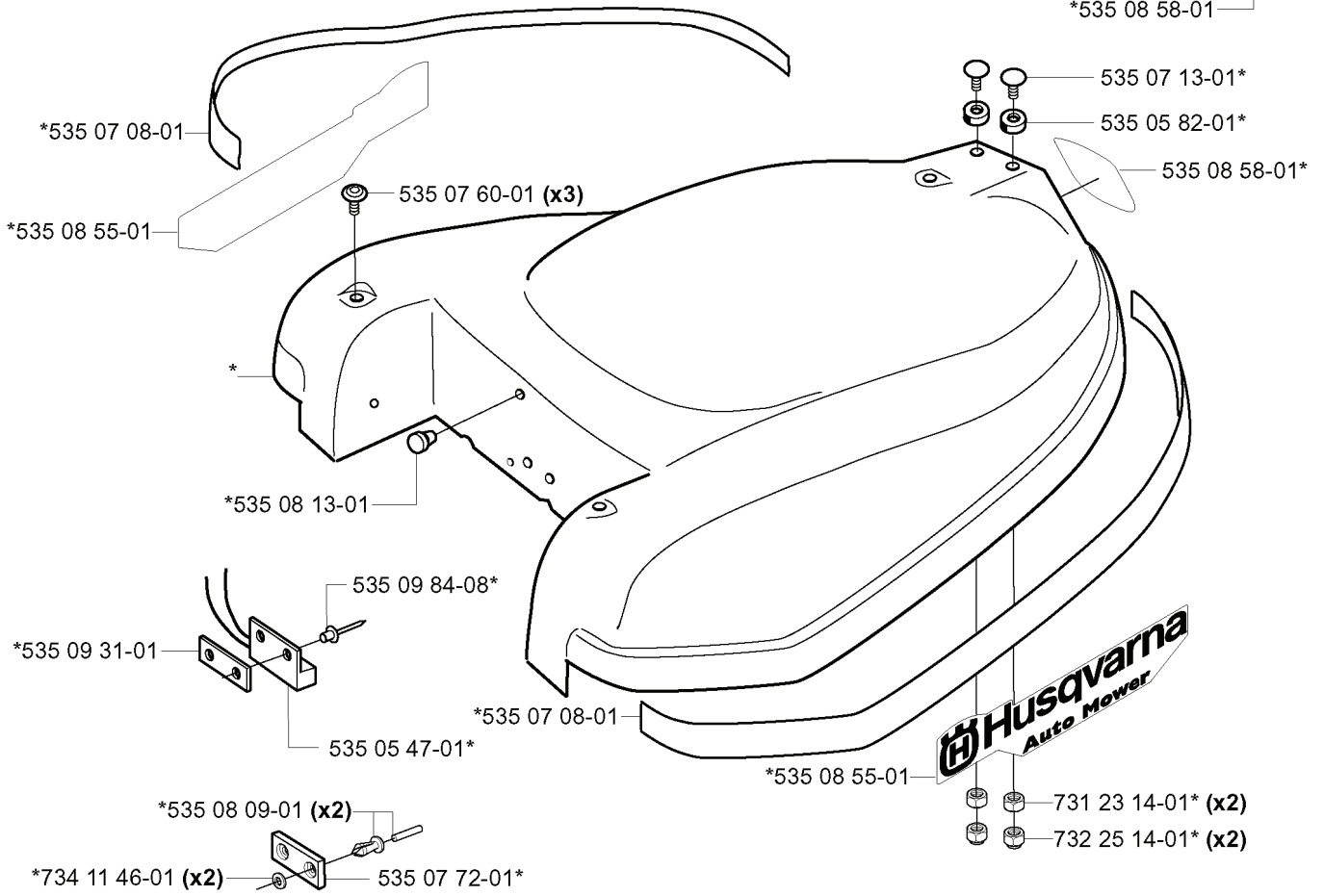

REF.	PART NO.	DESCRIPTION	REMARK	QTY.	KIT
535 09 77-01	535097701	COVER		1	
535 09 31-01	535093101	WASHER		1	
535 08 09-01	535080901	RIVET		2	
734 11 46-01	734114601	WASHER		2	
535 07 72-01	535077201	RAIL		1	
535 05 47-01	535054701	SWITCH		1	
535 07 08-01	535070801	TAPE		1	
535 09 84-08	535098408	RIVET		1	
535 08 13-01	535081301	BUFFER		1	
535 07 60-01	535076001	SCREW		3	
535 08 55-01	535085501	DECAL		1	
732 25 14-01	732251401	HEXAGON LOCKING NUT		2	
731 23 14-01	731231401	HEXAGON NUT		2	
535 05 82-01	535058201	WASHER		1	
535 07 13-01	535071301	SCREW		1	
535 08 58-01	535085801	DECAL		1	

G

****compl 535 09 13-01**

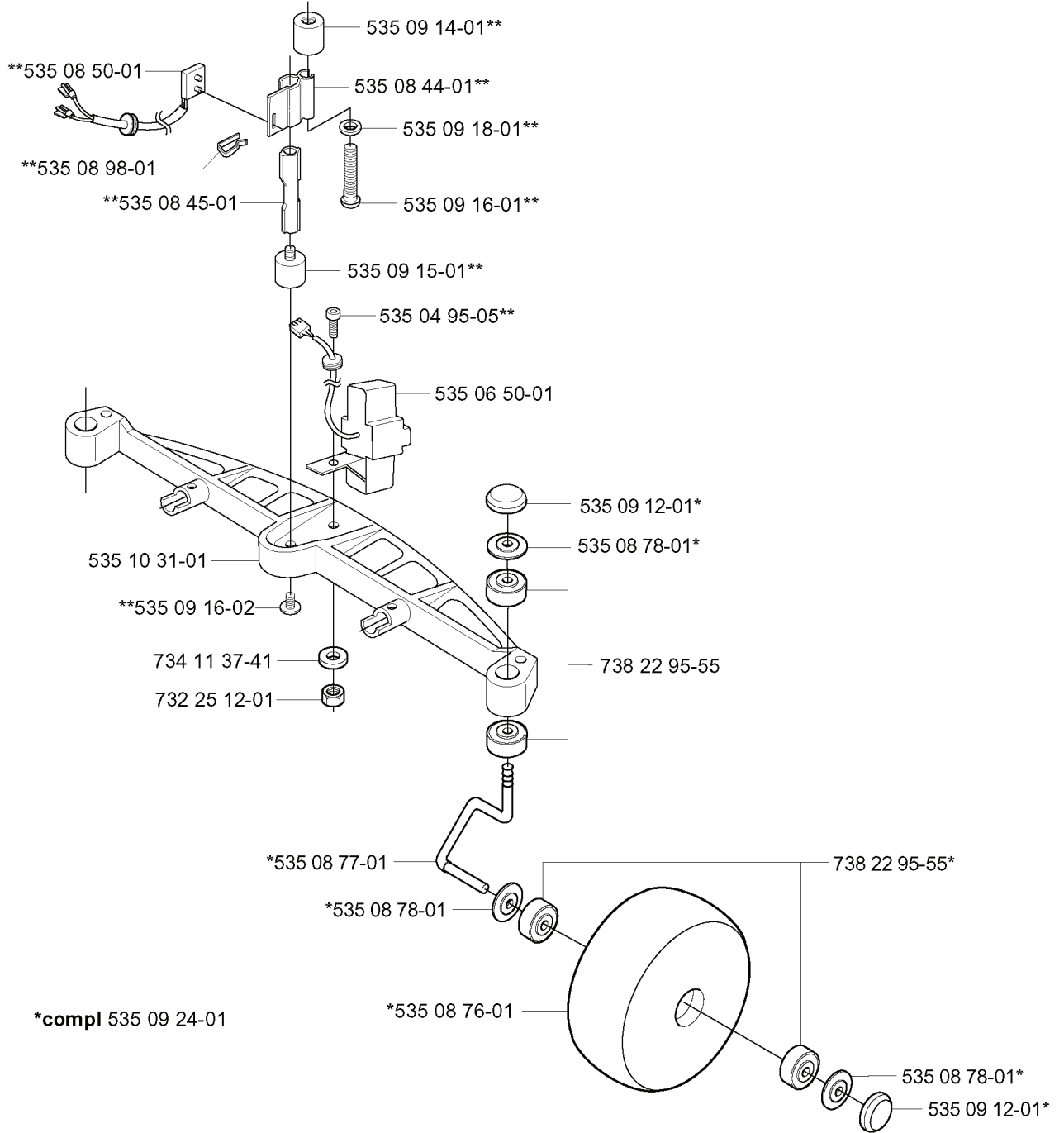

***compl 535 09 24-01**

REF.	PART NO.	DESCRIPTION	REMARK	QTY.	KIT
535 09 13-01	535091301	LIFT SENSOR		1	
535 08 50-01	535085001	CABLE ASSY		1	
535 08 98-01	535089801	CLIP		1	
535 08 45-01	535084501	ROD		1	
535 10 31-01	535103101	BRACKET		1	
535 09 16-02	535091602	SCREW		1	
734 11 37-41	734113741	WASHER		1	
732 25 12-01	732251201	HEXAGON LOCKING NUT		1	
535 08 77-01	535087701	SPINDLE SHAFT		1	
535 08 78-01	535087801	COVER WASHER		1	
535 09 24-01	535092401	WHEEL		1	
535 08 76-01	535087601	WHEEL		1	
535 09 12-01	535091201	WASHER		1	
738 22 95-55	738229555	BALL BEARING		1	
535 06 50-01	535065001	SENSOR		1	
535 04 95-05	535049505	SCREW IH PANM		1	
535 09 15-01	535091501	BUMPER		1	
535 09 16-01	535091601	SCREW		1	
535 09 18-01	535091801	WASHER		1	
535 08 44-01	535084401	BRACKET		1	
535 09 14-01	535091401	DAMPER		1	

D

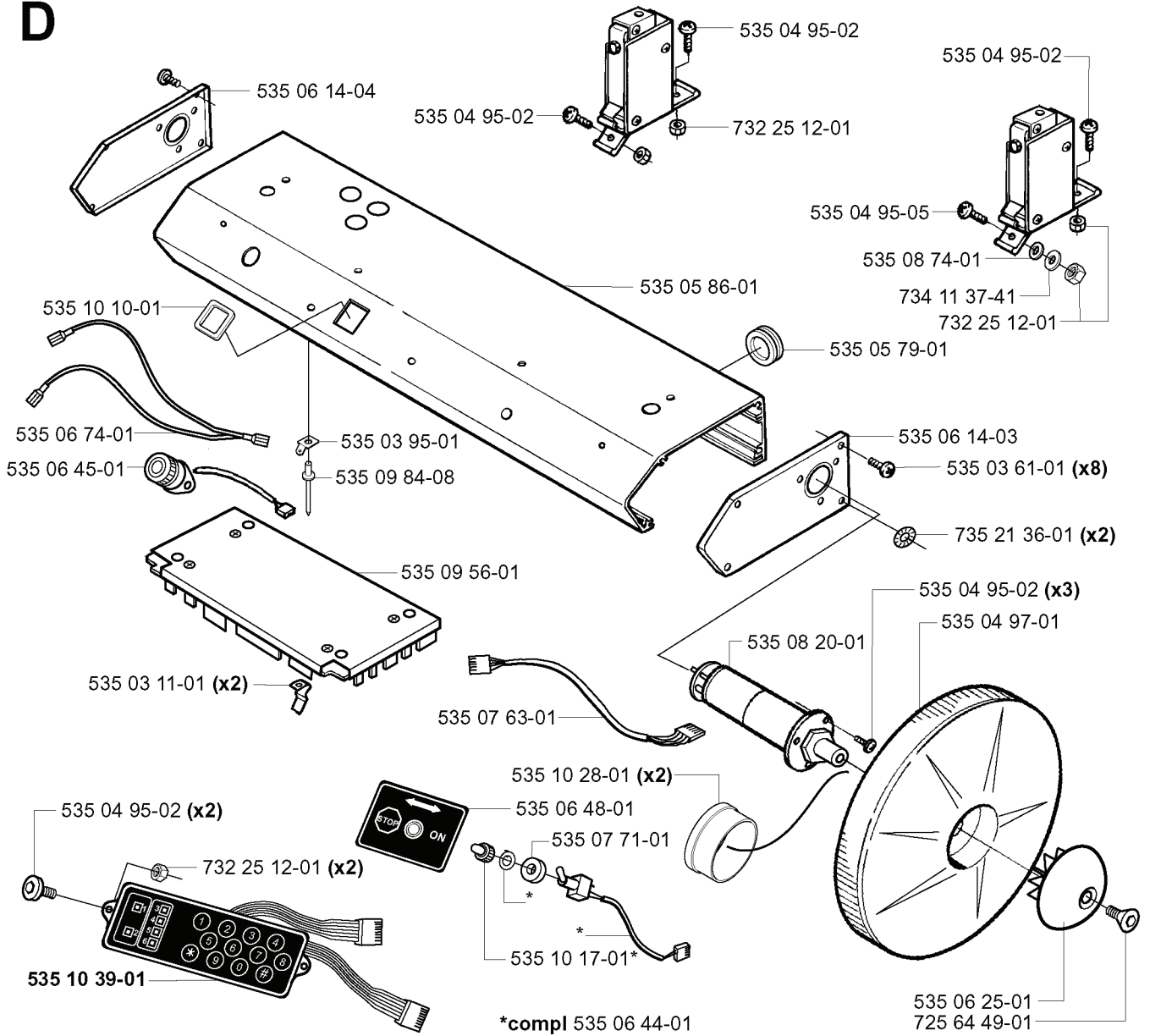

REF.	PART NO.	DESCRIPTION	REMARK	QTY.	KIT
535 06 14-04	535061404	END		1	
535 10 10-01	535101001	GASKET		1	
535 06 74-01	535067401	CABLE		1	
535 06 45-01	535064501	BUZZER		1	
535 03 11-01	535031101	SPRING		2	
535 10 39-01	535103901	KEYBOARD		1	
535 06 44-01	535064401	SWITCH		1	
535 10 17-01	535101701	SWITCH		1	
535 07 71-01	535077101	WASHER		1	
535 06 48-01	535064801	DECAL		1	
535 10 28-01	535102801	PROTECTION		2	
535 07 63-01	535076301	CABLE ASSY		1	
535 09 56-01	535095601	PRINTED CIRCUIT ASSY		1	
535 09 84-08	535098408	RIVET		1	
535 03 95-01	535039501	CLIP		1	
535 04 95-02	535049502	SCREW IH PANM		1	
535 05 86-01	535058601	BOX		1	
535 08 20-01	535082001	ENGINE	Motor w/o gearbox 535 10 66-01	1	
725 64 49-01	725644901	SCREW IH CSFM		1	
535 06 25-01	535062501	WASHER		1	
535 04 97-01	535049701	GEAR WHEEL		1	
735 21 36-01	735213601	LOCKWASHER		2	
535 03 61-01	535036101	SCREW		8	
535 06 14-03	535061403	END		1	
535 05 79-01	535057901	GROMMET		1	
732 25 12-01	732251201	HEXAGON LOCKING NUT		1	
734 11 37-41	734113741	WASHER		1	
535 08 74-01	535087401	WASHER		1	
535 04 95-05	535049505	SCREW IH PANM		1	

C

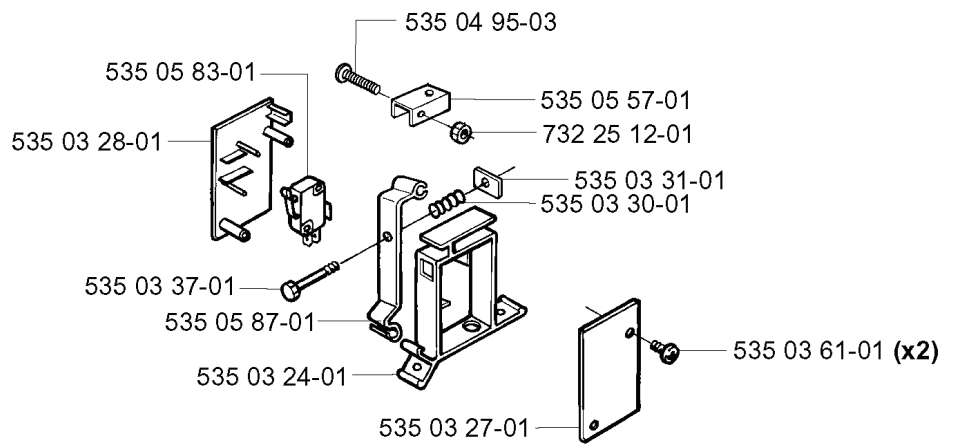
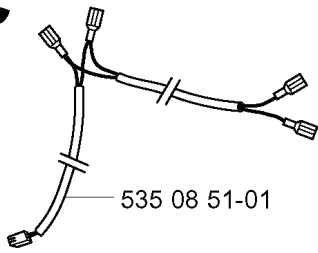

REF.	PART NO.	DESCRIPTION	REMARK	QTY.	KIT
535 08 51-01	535085101	CABLE ASSY		1	
535 05 83-01	535058301	SWITCH		1	
535 03 28-01	535032801	COVER		1	
535 03 37-01	535033701	SCREW		1	
535 05 87-01	535058701	LEVER		1	
535 03 24-01	535032401	BRACKET		1	
535 03 27-01	535032701	COVER		1	
535 03 61-01	535036101	SCREW		2	
535 03 30-01	535033001	SPRING		1	
535 03 31-01	535033101	NUT		1	
732 25 12-01	732251201	HEXAGON LOCKING NUT		1	
535 05 57-01	535055701	BRACKET		1	
535 04 95-03	535049503	SCREW IH PANM		1	

E

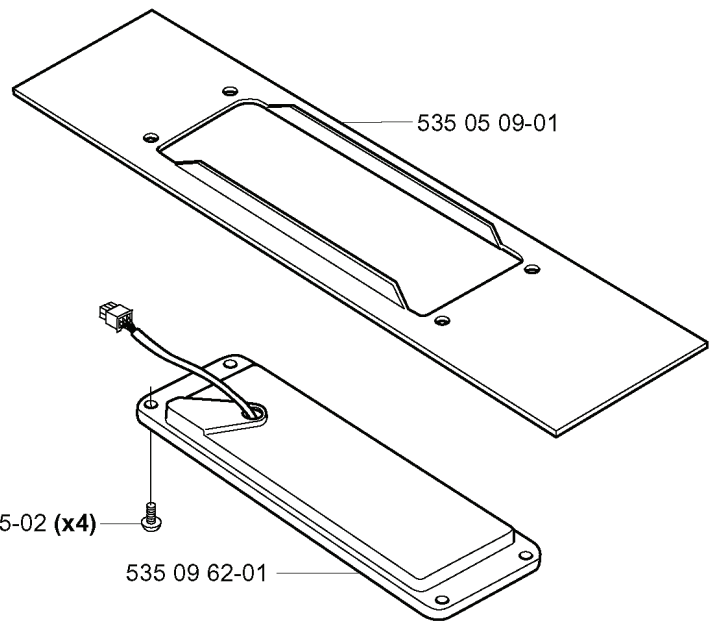
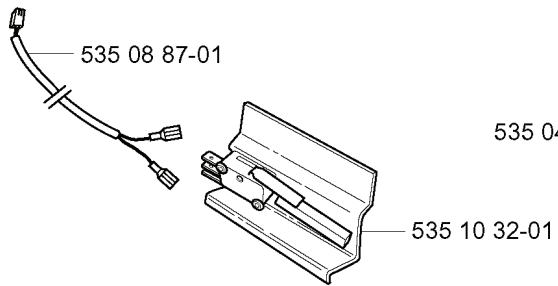
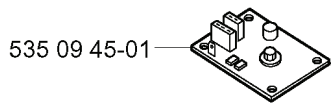
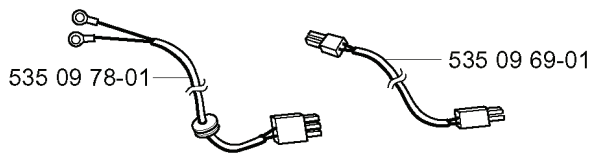

REF.	PART NO.	DESCRIPTION	REMARK	QTY.	KIT
535 09 78-01	535097801	CABLE		1	
535 09 45-01	535094501	PRINTED CIRCUIT CARD		1	
535 08 87-01	535088701	CABLE ASSY		1	
535 10 32-01	535103201	SWITCH		1	
535 04 95-02	535049502	SCREW IHANM		4	
535 09 62-01	535096201	BATTERY		1	
535 09 69-01	535096901	CABLE ASSY		1	
535 05 09-01	535050901	COVER		1	

J

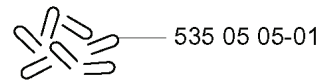
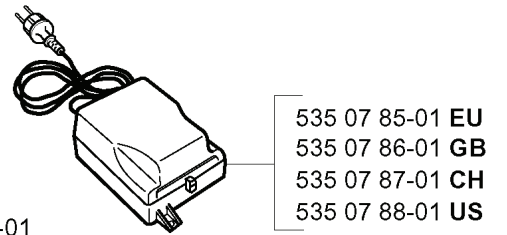
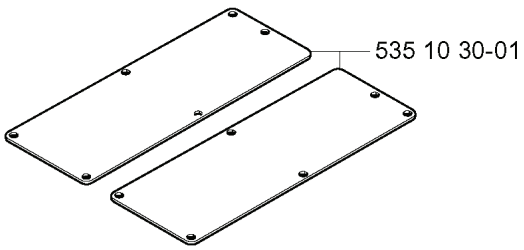
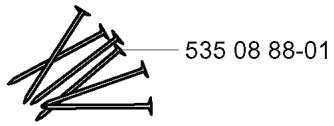
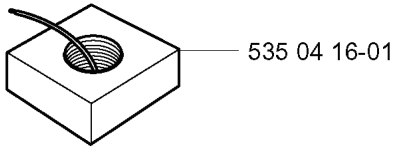

REF.	PART NO.	DESCRIPTION	REMARK	QTY.	KIT
535 04 16-01	535041601	WIRE		1	
535 08 88-01	535088801	PIN RETAINING SCREW		1	
535 10 30-01	535103001	PLATE		1	
535 10 35-01	535103501	PLASTIC CARD KIT		1	
535 05 05-01	535050501	STAPLE		1	
535 07 88-01	535078801	TRANSFORMER	US	1	
535 07 87-01	535078701	TRANSFORMER	CH	1	
535 07 86-01	535078601	TRANSFORMER	GB	1	
535 07 85-01	535078501	TRANSFORMER	EU	1	
535 07 89-01	535078901	WIRE		1	

H

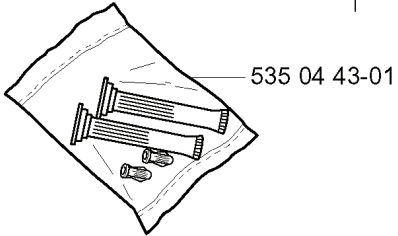
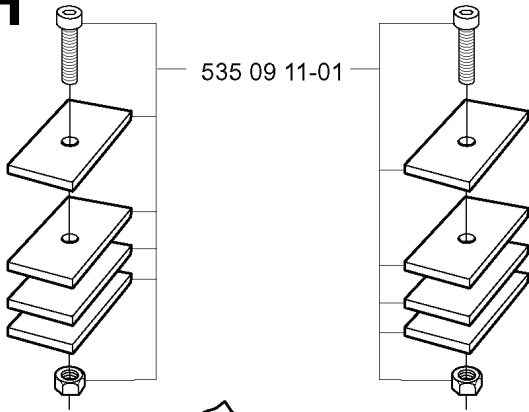

505 69 99-90



REF.	PART NO.	DESCRIPTION	REMARK	QTY.	KIT
535 09 11-01	535091101	COUNTERWEIGHT		1	
535 04 43-01	535044301	COUPLER		1	
505 69 99-90	505699990	BAG		1	

REF.	PART NO.	DESCRIPTION	REMARK	QTY.	KIT
535 09 88-01	535098801	COVER		1	
535 06 81-01	535068101	SPRING		1	
535 07 51-01	535075101	DECAL		1	
535 08 56-01	535085601	BUMPER		1	
535 07 65-01	535076501	DECAL		1	
535 06 72-01	535067201	COVER		1	
535 06 78-01	535067801	RIVET		3	
732 25 14-01	732251401	HEXAGON LOCKING NUT		1	
535 07 02-01	535070201	BUSHING		1	
535 09 31-01	535093101	WASHER		1	
725 23 33-71	725233371	SCREW EHHM		1	
535 09 84-08	535098408	RIVET		1	
535 05 47-02	535054702	MAGNET		1	

F

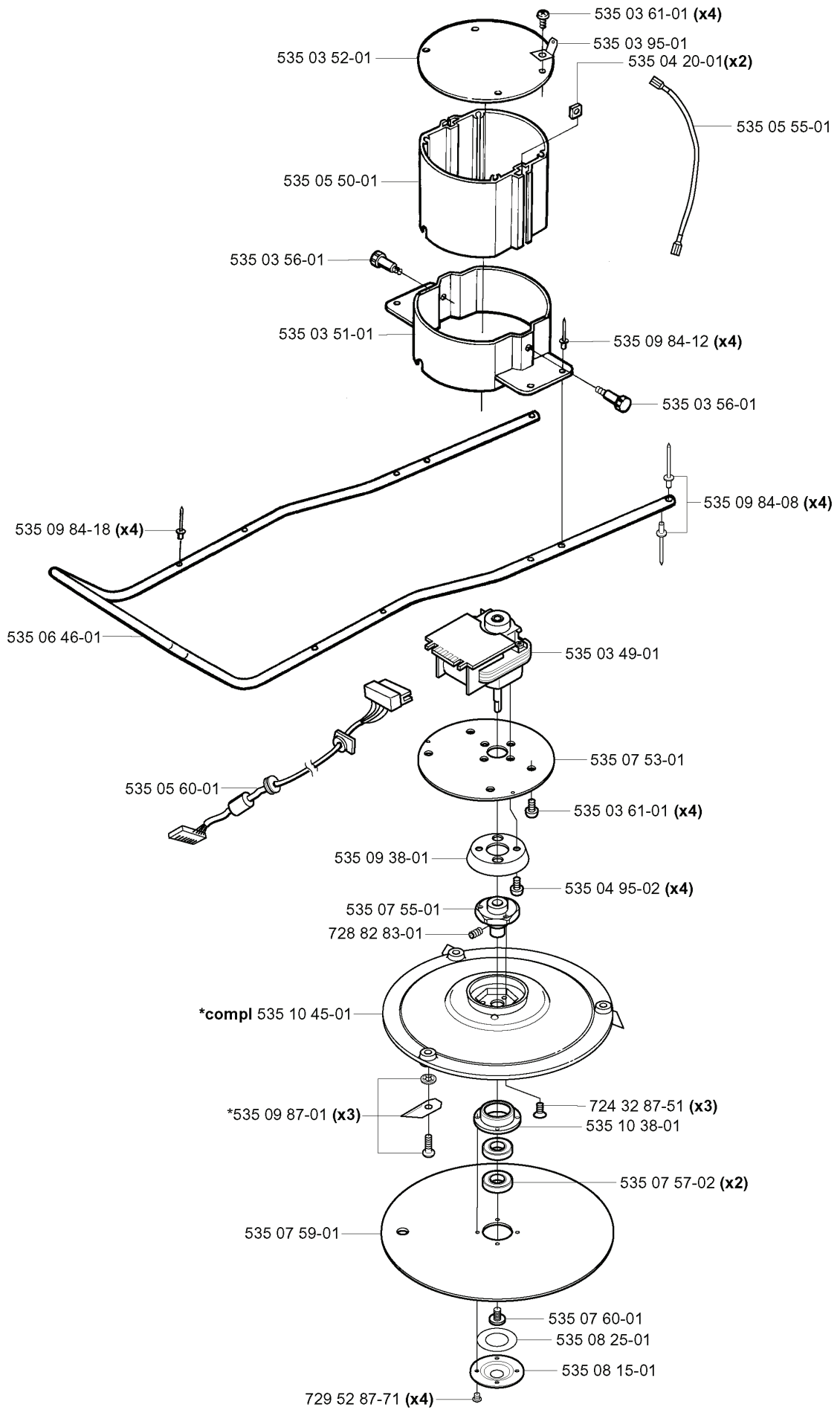

REF.	PART NO.	DESCRIPTION	REMARK	QTY.	KIT
535 03 52-01	535035201	COVER		1	
535 05 50-01	535055001	PIPE		1	
535 03 51-01	535035101	PIPE		1	
535 09 84-18	535098418	RIVET		4	
535 06 46-01	535064601	PIPE		1	
535 05 60-01	535056001	CABLE		1	
535 09 38-01	535093801	PROTECTION		1	
535 07 55-01	535075501	HUB		1	
728 82 83-01	728828301	SCREW IHSETM		1	
535 10 45-01	535104501	BLADE DISC		1	
535 09 87-01	535098701	BLADE SET		3	
535 07 59-01	535075901	SKID PLATE		1	
729 52 87-71	729528771	SCREW CCRPANT		4	
535 08 15-01	535081501	COVER WASHER		1	
535 08 25-01	535082501	GASKET		1	
535 07 60-01	535076001	SCREW		1	
535 07 57-02	535075702	BALL BEARING		2	
535 07 57-02	593080801	BALL BEARING	Tube 50 pcs	1	
535 10 38-01	535103801	HOLDER		1	
724 32 87-51	724328751	SCREW CRCFSM		3	
535 04 95-02	535049502	SCREW IH PANM		4	
535 03 61-01	535036101	SCREW		4	
535 07 53-01	535075301	PLATE		1	
535 03 49-01	535034901	ENGINE		1	
535 09 84-08	535098408	RIVET		4	
535 03 56-01	535035601	KNOB		1	
535 09 84-12	535098412	RIVET		4	
535 05 55-01	535055501	CABLE		1	
535 04 20-01	535042001	NUT		2	
535 03 95-01	535039501	CLIP		1	

L TYPE B
***compl 535 09 10-01**

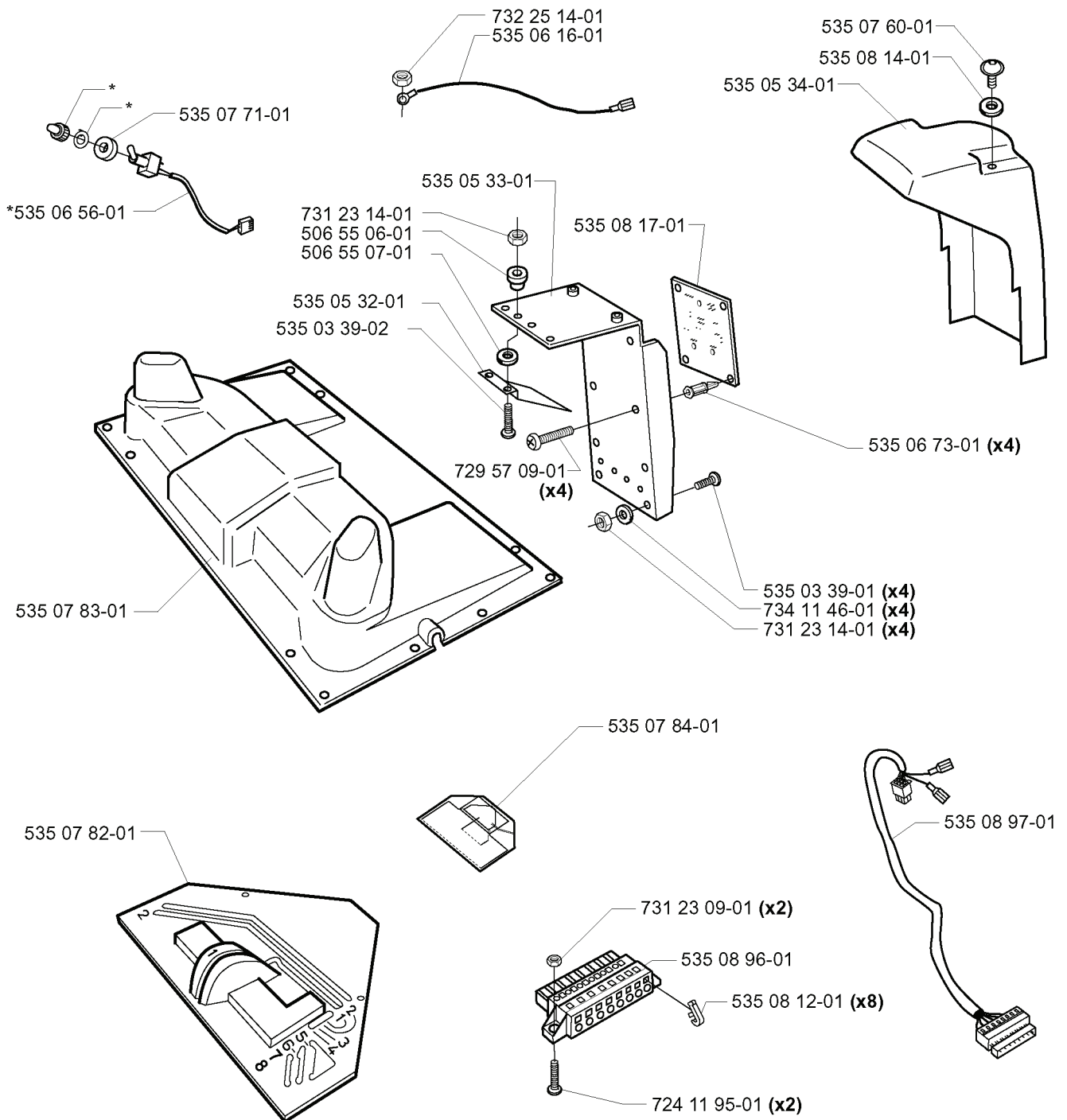

REF.	PART NO.	DESCRIPTION	REMARK	QTY.	KIT
535 09 10-01	535091001	CHARGING STATION		1	
535 10 41-01	535104101	CHARGING STATION		1	
535 09 39-01	535093901	COVER		1	
535 09 63-01	535096301	CABLE ASSY		1	
535 07 83-01	535078301	COVER		1	
729 52 26-71	729522671	SCREW CRPANT		1	
535 07 82-01	535078201	PLATE		1	
535 03 39-02	535033902	SCREW IH PANM		1	
535 09 66-01	535096601	PLATE		1	
535 05 32-01	535053201	PLATE		1	
535 10 15-01	535101501	PROTECTION		2	
535 10 05-01	535100501	RAMP		1	
535 09 42-01	535094201	GROMMET		3	
535 09 65-01	535096501	DECAL		1	
535 05 33-01	535053301	BRACKET		1	
729 57 09-01	729570901	SCREW CCRPANT		4	
506 55 07-01	506550701	INSULATING WASHER		1	
732 25 14-01	732251401	HEXAGON LOCKING NUT		1	
535 07 71-01	535077101	WASHER		1	
535 08 17-01	535081701	PRINTED CIRCUIT CARD		1	
535 09 68-01	535096801	BRACKET		1	
535 06 56-01	535065601	SWITCH		1	
535 07 84-01	535078401	DECAL		1	
535 07 60-01	535076001	SCREW		2	
731 23 09-01	731230901	HEXAGON NUT		2	
535 08 14-01	535081401	WASHER		2	
535 08 96-01	535089601	CONNECTION		1	
535 09 47-01	535094701	COVER		1	
535 08 12-01	535081201	TRIGGER		8	
535 10 36-01	535103601	CONTACT		1	
724 11 95-01	724119501	SCREW CR PANM		2	
535 08 97-01	535089701	CABLE ASSY		1	
506 55 06-01	506550601	PLUG		1	
734 11 46-01	734114601	WASHER		4	
731 23 14-01	731231401	HEXAGON NUT		4	
535 09 72-01	535097201	HOSE		3	
535 05 34-01	535053401	COVER		1	
535 10 11-01	535101101	MANDREL		1	
535 03 39-01	535033901	SCREW IH PANM		4	
535 06 16-01	535061601	CABLE		1	
535 06 73-01	535067301	SPACER		4	